



# Summary and Evaluation of Existing Data on Air Staging Strategies

## Report

## Project ERA-NET “Future BioTec”

Project coordinator: Ingwald Obernberger

Prepared by: Fritz Biedermann, Thomas Brunner, Ingwald Obernberger, Olli Sippula, Christoffer Boman, Marcus Öhman, Linda Bäfver

Date: September 2010



## Contents

- **Executive summary**
- **Air Staging Strategies in Austria (prepared by BIOENERGY 2020+)**
  - Pellet boiler technology (nominal boiler capacity: 12, 18 and 24 kW<sub>th</sub>)
  - Low-NO<sub>x</sub> pilot-scale combustion plant (nominal boiler capacity: 440 kW<sub>th</sub>)
  - Multi-fuel-/low-dust combustion technology (nominal boiler capacity: 9.2 MW<sub>th</sub>)
  - Results from literature research
- **Air Staging Strategies in Switzerland (based on literature data from Nussbaumer et. al.)**
  - Test runs at a prototype biomass combustion plant (nominal boiler capacity: 250 kW<sub>th</sub>, target NO<sub>x</sub> emission reduction)
  - Test runs performed at a underfeed stoker furnace (target: TSP emission reduction)
- **Air Staging Strategies in Finland (prepared by University of Eastern Finland)**
  - Residential pellet boiler technology (nominal boiler capacity: 25 kW<sub>th</sub>)
  - Pellet burner technology based on gasification and combustion (nominal boiler capacity: 15 kW)
- **Air Staging Strategies in Sweden (prepared by Umeå University, Luleå University of Technology and SP Technical Research Institute)**
  - Modified commercial residential pellet stove (nominal boiler capacity: 6 kW<sub>th</sub>)
  - Residential pellet burner + lab. reactors (nominal boiler capacity: 15 kW<sub>th</sub>)
  - Research reactor for grate combustion of pellets (nominal boiler capacity: 5 kW<sub>th</sub>)
  - Grate fired furnace for wet and inhomogeneous biomass fuels (nominal boiler capacity: 500 kW<sub>th</sub>)



# Executive Summary



## Summary (I) – Overview

- This report summarizes and evaluates available data regarding the influence of air staging on  $\text{NO}_x$  and PM emissions for fixed bed biomass combustion systems
- The compilation of this report was coordinated by BIOENERGY 2020+ GmbH
- The following partners contributed to the report:
  - BIOENERGY 2020+ GmbH, Austria
  - University of Eastern Finland
  - Umeå University, Luleå University of Technology and SP Technical Research Institute, Sweden
- In total, data from 9 different automated boiler technologies with a nominal boiler capacity between  $5 \text{ kW}_{\text{th}}$  und  $9.2 \text{ MW}_{\text{th}}$  have been evaluated
- In addition, literature data from Austria and Switzerland have been considered
- In general, the results of this report show that up to now no reliable data regarding comprehensive systematic studies on air staging strategies are available which stresses the importance of the air staging tests planned within the scope of the project “ERA-NET FutureBioTec”



## Summary (II) – Definitions (air ratios)

- $\lambda_{\text{tot}}$  **total excess air ratio**  
calculated from fuel, primary air and secondary air flows
- $\lambda_{\text{primary}}$  **air ratio related to the primary combustion zone**  
calculated from fuel and oxidising agents supplied in the primary combustion chamber (air, recirculated flue gas)

If flue gas recirculation is applied, the following definitions are of relevance:

When flue gas is recirculated below the grate:

- $\lambda_{\text{grate}}$  **air ratio related to the conditions on the grate**  
considering the fuel, primary air and flue gas recirculation below the grate

When flue gas is recirculated above the fuel bed but within the primary combustion zone

- $\lambda_{\text{above bed}}$  **air ratio related to the conditions above the fuel bed**  
considering the fuel, primary air and flue gas recirculation below as well as above the grate



## Summary (III) – Definitions (false air, N-conversion and element release)

### False air:

Air streams into the furnace which are not supplied by the primary and secondary air nozzles. False air usually occurs at the fuel feeding system, the cleaning doors and the ignition system

### N conversion ratio:

N bound in  $\text{NO}_x$  emissions [moles/h] / N in the fuel [moles/h]

### Element release from the fuel to the gas phase:

Release ratio of an element  $i = R_i$

$$R_i = m_{i,\text{released}} / m_{i,\text{fuel}} * 100\%$$

$$(1) m_{i,\text{released}} = (m_{i,\text{aerosols}} + m_{i,\text{ash vapours at boiler outlet}})$$

$$(2) m_{i,\text{released}} = (m_{i,\text{fuel}} - (m_{\text{ash,fuel}} * m_{i,\text{bottom ash}} / m_{\text{bottom ash}}))$$

$m$  ... mass flow [kg/h or kg/kg fuel]

**→ At least mass balances as well as fuel and ash analyses are needed to estimate the release of a certain element**



## Summary (IV) – Results from BIOENERGY 2020+ (Austria) – Pellet boiler technology

### ■ Technological description (summary):

- **Manufacturer: VISSMANN Werke GmbH & Co KG**
- **Fuel: softwood pellets**
- **Nominal boiler capacity: 12, 18 and 24 kW<sub>th</sub>**
- **Overfeed burner system with grate (rotated for ash removal every 12 hours)**
- **Separated primary and secondary combustion chamber (primary zone very small)**
- **Separate control of primary and secondary air flow by valves**
- **No flue gas recirculation**
- **Amount of false air was not determined within the scope of the measurements presented. Other measurements performed at this pellet boiler technology showed that the false air amounts to approx. 20 – 40% of the total air amount (at full load)**
- **Residence time in the primary combustion chamber at full load: approx. 0.01s**
- **Estimated temperature in the primary combustion chamber at full load: not determined**



## Summary (V) – Results from BIOENERGY 2020+ (Austria) – Pellet boiler technology

### ■ Measurements performed:

- Measurement of the gaseous and particulate emissions at different load conditions
- Determination of the primary and total air ratio

### ■ Results/conclusions:

- CO (20 mg/MJ) and particulate emissions (9 – 15 mg/MJ) at 24 and 18 kW load are at comparable levels with state-of-the-art pellet boilers
- NO<sub>x</sub> emissions amount to 95 mg/MJ and are at a comparatively high level at full load compared to state-of-the-art pellet boilers (77 mg/MJ). This is probably due to the small primary combustion zone
- At 3.6 kW load considerable formation of soot and tar occurred. Particulate emissions were above 50 mg/MJ
- CO emissions also considerably increase at 3.6 kW compared to full load (104 mg/MJ)
- The air ratio in the primary combustion zone is approx. 0.5 at full load and approx. 1.0 at partial load
- Optimization of the position of the secondary air inlets in order to increase the size of the primary combustion chamber should lead to a considerable reduction potential regarding NO<sub>x</sub> emissions





## Summary (VI) – Results from BIOENERGY 2020+ (Austria) - Low-NO<sub>x</sub> pilot-scale combustion plant (2 plant concepts)

### ■ Technological description (summary):

- **Manufacturer: MAWERA Holzfeuerungsanlagen**
- **Fuel: wood chips, waste wood, chipboard residues**
- **Nominal boiler capacity: 440 kW<sub>th</sub>**
- **Travelling grate (plant I) and horizontally moving grate (plant II)**
- **Separated primary and secondary combustion chamber**
- **Primary and the secondary air fans can be controlled independently**
- **Flue gas recirculation above and below the grate**
- **Amount of false air was not determined**
- **Residence time in the primary combustion chamber at full load: 0.5 – 0.8 s**
- **Estimated temperature in the primary combustion chamber at full load: 800 – 1,100 °C**

### ■ Research performed:

- **Investigation of NO<sub>x</sub> formation processes in grate-fired biomass combustion systems**

### ■ Methodology applied:

- **Experimental investigations at the pilot-scale plants**
- **Lab-reactor tests regarding the release of NO<sub>x</sub>-precursors**
- **Investigations regarding gas-phase kinetics of NO<sub>x</sub> formation**



## Summary (VII) – Results from BIOENERGY 2020+ (Austria) - Low-NO<sub>x</sub> pilot-scale combustion plant (2 plant concepts)

### ■ Results/conclusions:

- The results gained from the project show clear tendencies concerning the effects of air staging on NO<sub>x</sub> reduction
  - A distinct NO<sub>x</sub> emission minimum could be identified in the  $\lambda_{\text{above bed}}$  range between 0.7 and 0.9 for plant II.
  - Also regarding the total air ratio an influence on NO<sub>x</sub> emissions could be identified. However, this could also have been due to an overlapping with the decreasing primary air ratios  
→ more systematic research is needed
  - NO<sub>x</sub> emission reduction efficiency increases with increasing residence time in the primary combustion zone
  - No relevant influence of the temperature in the primary combustion chamber on NO<sub>x</sub> emissions could be detected
- The influence of false air was not investigated within this project
- No data concerning the influence of air ratios on total dust and PM<sub>1</sub> emissions are available from this research
- The lab-reactor tests performed showed that for chipboard the most relevant NO<sub>x</sub> precursor is NH<sub>3</sub> (HCN is not relevant)
- Calculations regarding gas-phase kinetics of NO<sub>x</sub> formation showed that for efficient NO<sub>x</sub> reduction the temperature should 950 to 1,000 °C and the O<sub>2</sub> content should be in the range 0,05 mol/mol in the primary combustion chamber



## Summary (VIII) – Results from BIOENERGY 2020+ (Austria) – multi-fuel/low-dust combustion technology

### ■ Technological description (summary):

- **Manufacturer: POLYTECHNIK Luft- und Feuerungstechnik GmbH**
- **Fuel: wood chips, wood dust, chipboard residues**
- **Nominal boiler capacity: 9.2 MW<sub>th</sub>**
- **Inclined moving grate**
- **Co-current flow concept with primary and secondary combustion zone**
- **Primary and secondary air fans can be controlled independently**
- **Flue gas is recirculated below and above the grate**
- **According to calculations performed the amount of false air in the plant is below 10%**
- **Residence time in the primary combustion chamber at full load: 0.50 – 0.71**
- **Estimated temperature in the primary combustion chamber at full load: 900 – 1,200 °C**

### ■ Research/measurements performed:

- **Within a research project 3 different biomass fuels were tested at the plant (mixture of wood chips and wood dust, chipboard residues and wood dust)**
- **The plant was operated at constant load conditions (almost full load) at the usual settings concerning total air ratio, flue gas recirculation and air staging (no variations of these parameters)**



## Summary (IX) – Results from BIOENERGY 2020+ (Austria) – multi-fuel/low-dust combustion technology

### ■ Results/conclusions:

- Primary air ratio ( $\lambda_{\text{above bed}}$ ): 0.75 for wood chips, 0.62 for wood dust and 0.50 for chipboard residues
- NO<sub>x</sub> emissions: 58 mg/MJ for wood chips, 58 mg/MJ for wood dust and 242 mg/MJ for chipboard
- TSP emissions: 101 mg/MJ for wood chips, 78 mg/MJ for wood dust and 225 mg/MJ for chipboard
- PM1 emissions: 24 mg/MJ for wood chips, 25 mg/MJ for wood dust and 34 mg/MJ for chipboard
- The concept represents a sound and appropriate solution for implementing air staging in medium-scale combustion plants in order to minimise NO<sub>x</sub> emissions and keep TSP emissions low
- For all fuels investigated low NO<sub>x</sub>, CO, TSP and PM<sub>1</sub> emissions were detected
- Highest NO<sub>x</sub>, TSP and PM<sub>1</sub> emissions occurred for chipboard residues due to highest N and ash content in the fuel

### ■ Potentials for optimisation

- Enlargement of the primary combustion zone (zone before secondary air injection) to achieve an even higher NO<sub>x</sub> reduction for N-rich fuels should be investigated.
- Control of the air staging (primary air ratio) also during partial load would be meaningful.
- Further reduction of the primary air ratio ( $\lambda_{\text{above bed}}$ ) in order to reduce the K-release from the fuel bed to the gas phase (→ reduction of PM<sub>1</sub> emission formation).



## Summary (X) – Results from BIOENERGY 2020+ (Austria) – results from literature research

### Results of CFD simulations performed at Graz University of Technology

#### ■ Objectives

- Development and verification of simulation models regarding NO<sub>x</sub> formation in biomass combustion plants. CFD-models applied: gas phase combustion model, empirical packed-bed model, k-ε model for turbulence, Eddy Dissipation Concept for turbulence-chemistry interaction and skeletal Kilpinen97 reaction mechanism

#### ■ Methods

- Simulations for varying primary air ratios in a 440 kW<sub>th</sub> grate furnace systems were performed
- Comparison with results from measurements performed with fibreboard as fuel

#### ■ Results

- Good agreement of simulated and measured NO<sub>x</sub> emissions
- A clear reduction of NO<sub>x</sub> emissions with decreasing primary and total air ratios was identified (two cases investigated:  $\lambda_{\text{primary}} = 1.63$ ; NO<sub>x</sub> emissions = 293 vppm and  $\lambda_{\text{primary}} = 0.97$ ; NO<sub>x</sub> emissions = 256 vppm)
- The reduction of the primary air ratio is limited by an increased tar-release and a poor burn-out
- Flue gas recirculation in the primary combustion zone leads to an effective mixing and a good temperature control in the zone
- The residence time in the primary combustion zone influences the NO<sub>x</sub> emissions. A residence time of about 0.7s is sufficient
- A backflow of secondary air into the primary combustion zone influences the residence time (decreasing) and mixing effects in the primary combustion zone and therefore should be avoided



## Summary (XI) – Results from research performed by Nussbaumer et. al.

### Research performed by Nussbaumer et. al. regarding NO<sub>x</sub> emission reduction

#### ■ Objectives

- Investigations regarding the influence of air staging and flue gas recirculation on NO<sub>x</sub> emission formation in an underfeed stoker fired biomass combustion system

#### ■ Methods

- Test runs at a 250 kW biomass combustion plant (prototype) with a separated primary and secondary combustion zone and flue gas recirculation mixed with the primary combustion air
- Fuels used: wood chips, chipboard residues
- Parameters investigated regarding influence on NO<sub>x</sub> emissions: total and primary air ratio, flue gas recirculation and application of an optimised control concept
- No false air measurements performed

#### ■ Results

- A separate primary combustion zone (reducing conditions) must be implemented in the furnace concept
- Significantly decreasing NO<sub>x</sub> emissions with decreasing  $\lambda_{\text{prim}}$
- No significant influence of flue gas recirculation on NO<sub>x</sub> emissions
- Optimised operation conditions for low-NO<sub>x</sub> operation at low CO emissions:  $\lambda_{\text{prim}}$ : 0.6 to 0.8;  $\lambda_{\text{total}}$ : 1.2 to 1.5; residence time in the primary combustion zone: >0.3 – 0.5 s; temperature in the primary combustion zone: 1,100 – 1,200°C
- NO<sub>x</sub> reduction potential by air staging: for fuels with low N-content (<0.5 wt% d.b.): 40 – 60%; for fuels with high N-content (>1 wt% d.b.): 50 – 75%



## Summary (XII) – Results from research performed by Nussbaumer et. al.

### Research performed by Nussbaumer et. al. regarding TSP emission reduction

#### ■ Objectives

- Investigation of parameters influencing TSP emissions from biomass combustion

#### ■ Methods

- Test runs at a 250 kW biomass combustion plant (prototype) with a separated primary and secondary combustion zone
- Fuels used: wood chips, chipboard residues, pellets
- Parameters investigated: different biomass fuels and primary air ratios
- No false air measurements performed

#### ■ Results

- TSP emissions can be reduced by a factor 5 by applying low primary air ratios.
- TSP emissions below 33 mg/MJ were achieved for most of the fuels used when applying primary air ratios around 0.3
- When firing biomass fuels with higher moisture content an even flow through the bed has to be guaranteed to minimise particle emissions (particle entrainment due to bed channelling)
- The lowest TSP emissions could be achieved for pellets. Beech wood chips and chipboard residues showed higher TSP emissions
- It is postulated that by reducing the primary air flow also the release of K as an aerosol forming element from the fuel to the gas phase and consequently aerosol emissions can be reduced. This has however not been confirmed by measurements



## Summary (XIII) – Results from University of Eastern Finland – pellet boiler technology

### ■ Technological description (summary):

- Manufacturer: Biotech GmbH
- Fuel: wood pellets and sawdust
- Nominal boiler capacity: 25 kW<sub>th</sub>
- Top feed burner system with fixed grate
- Separated primary and secondary combustion chamber (primary zone is very small)
- Primary and secondary air input controlled by separate fans
- Amount of false air was not determined
- No flue gas recirculation applied

### ■ Research/measurements performed:

- Effect of primary and secondary air settings on fine particle and gas emissions in small-scale pellet appliances

### ■ Results/conclusions:

- Air staging has a large effect on PM1 emissions (reduction from 12 mg/MJ to 3 mg/MJ)
- NO<sub>x</sub> emissions amount to approx. 75 mg/MJ
- Decreased particle and CO emissions with decreased primary air. Opposite results with decreased secondary air
- Primary and total air ratios achieved in real operation:  
Total air ratios (1.9 full load; 2.7 50% load) and calculated primary air ratios (0.6 full load; 1.2 50% load)
- Decrease in power output must be considered when decreasing primary air flow rate





## Summary (XIV) – Results from University of Eastern Finland – pellet burner based on gasification and combustion

### ■ Technological description (summary):

- **Manufacturer: Pyroman Oy**
- **Fuel: wood pellets**
- **Nominal boiler capacity: 15 kW<sub>th</sub>**
- **Top feed burner system with gasification chamber and separated burner**
- **Primary air is supplied in the gasification chamber, secondary and tertiary air in the burner system**
- **Boiler technology can be mounted in biomass and oil boilers**
- **Primary, secondary and tertiary air input controlled only by one fan**
- **Amount of false air was not determined**
- **No flue gas recirculation applied**

### ■ Research/measurements performed:

- **Determination of fine particle and gaseous emissions of a pellet burner based on counter-draft gasification**

### ■ Results/conclusions:

- **Very low PM1, TSP and CO emissions (PM1 emissions: 1.3-2.4 mg/MJ)**
- **PM1 consists entirely of inorganic elements**
- **The release of alkali metals from the fuel bed is very low**
- **Total air ratio: 1.6 – 1.7**



## Summary (XV) – Results from Umeå University (Sweden) – modified commercial residential pellet stove

### ■ Technological description (summary):

- Manufacturer: Pitekaminen
- Fuel: wood pellets
- Nominal boiler capacity: 6 kW<sub>th</sub>
- Fixed grate
- Cylindrical combustion chamber with separated primary and secondary combustion zone
- Air ratio, temperature and residence time in the primary combustion chamber: not measured

### ■ Research/measurements performed:

- To demonstrate the possibilities to minimize the (fine) particle emissions from a commercial stove without significant reduction of other properties of the stove such as thermal efficiency and emissions of unburned gases
- Parameters studied: open area of the grate, additional secondary air inlets in the combustion chamber, insulation of the window

### ■ Results/conclusions:

- For the tested stove (Pitekaminen), both the soot particle and the fly ash particle concentrations were significant affected by the air flow rate through the grate
- The “soot” particle concentration (carbon content) was significantly affected by the air distribution in the combustion chamber and finally, the “soot” particle concentration was significant reduced when the window was insulated at 3.7 kW but not at 6.2 kW
- The construction changes performed in this work (open area of the grate, additional secondary air inlets and insulation of the window) suggested that it is possible to reduce the particle emissions up to 60 % at 3.7 kW and up to 30 % at 6.2 kW



## Summary (XVI) – Results from Umeå University (Sweden) – Research on commercial residential pellet burner and lab-reactors

### ■ Technological description (summary):

- Fuel: wood pellets
- Nominal boiler capacity: up to 15 kW<sub>th</sub>
- Grate technology varies between different appliances used
- No flue gas recirculation applied
- No false air measurements performed

### ■ Research/measurements performed:

- To study critical parameters for optimisation of NO<sub>x</sub>, OGC and CO emissions from pellet burners, both by experiments and kinetic modelling

### ■ Methodology applied:

- The project was divided into 4 stages: gas analyses in the combustion zone of a modified commercial pellet burner, computer simulations (Chemkin) to study proper reaction times and temperatures for optimal NO<sub>x</sub> reduction, laboratory reactor studies and demonstration in a prototype burner

### ■ Results/conclusions:

- The results indicate that the air ratio in the primary zone should be between 0.4 and 0.8, the temperature between 900 and 1,100 °C and the residence time for the gas in the primary zone about 0.3 s
- As a result from the simulations, an optimal temperature for NO reduction was found to be about 900 °C and the residence time in the primary zone should be about 0.3 s
- Compared to the modified commercial burner, the NO<sub>x</sub> emission decreased by 45% for the experimental prototype burner (from approx. 180 to 100 mg/MJ at a total air ratio of 1.9)



## Summary (XVII) – Results from Umeå University (Sweden) – research reactor (5 kW) for grate combustion of pellets

### ■ Technological description (summary):

- Fuel: wood pellets
- Nominal boiler capacity: up to 10 kW<sub>th</sub>
- Fixed grate
- Cylindrical combustion chamber with separated primary and secondary combustion zone
- No flue gas recirculation applied
- No false air measurements

### ■ Focus of research performed:

- Formation of aerosols from wood pellet combustion (detailed measurements of high temperature aerosols, influence of fuel ash type on high temperature aerosols, formation of supermicron particles (> 10 µm), vaporisation of metals by chemical equilibrium model calculations)
- Particle emission minimisation during wood pellets combustion (influence of combustion aerodynamics and temperature, influence of fuel type, influence of air supply strategy)

### ■ Results/conclusions:

- Increasing combustion temperature increases the formation of submicron fly ash particles (by a factor of approx. 2 from 700 to 950 °C). However, the emission of soot decreases
- The temperature and the flow pattern in the combustion zone affect the particle emissions
- In addition to the operating conditions significant differences in particle emissions were found between different biomass fuels
- For the particles that were dominated by inorganic elements the particle emissions were correlated to the ash concentration in the unburned fuel
- Furthermore, the results showed that in general the fuel type affects the inorganic particle emissions more than the influence from different operating and construction parameters



## Summary (XVIII) – Results from Umeå University (Sweden) – 500 kW grate fired furnace

### ■ Technological description (summary):

- Manufacturer: Swebo Bioenergy
- Fuel: wood chips with high moisture content (approx. 58 wt%) and horse manure
- Nominal boiler capacity range: 500 kW<sub>th</sub>
- Fixed grate
- Separated primary and secondary combustion zone
- Controllable primary to secondary air input
- No flue gas recirculation applied
- No false air measurements
- Air ratio in the primary combustion chamber: 0.7 – 1.0 (at 350 kW), 0.9 – 1.3 (at 150 kW)

### ■ Research performed:

- Evaluate the performance of the combustion chamber at constant thermal output
- Experiments with different settings of the ratio between front and side primary air as well as the ratio between total primary and secondary air

### ■ Results/conclusions:

- The experiments show very good results over the entire thermal output range. In the range 60 kW up to 500 kW, the average CO content in the stack gases is typically below 25 mg Nm<sup>3</sup> (20 ppm) and the NO<sub>x</sub> concentration below 195 mg/Nm<sup>3</sup> (95 ppm) during steady state conditions. At lower thermal outputs, the average CO content is below 105 mg/Nm<sup>3</sup> (84 ppm). All values standardised to 10 vol% O<sub>2</sub>, dry flue gas



## Summary (XIV) – present state-of-the-art regarding the conversion of fuel-N into NO<sub>x</sub> emissions

Results from various measurements performed at biomass grate combustion plants equipped with air staging

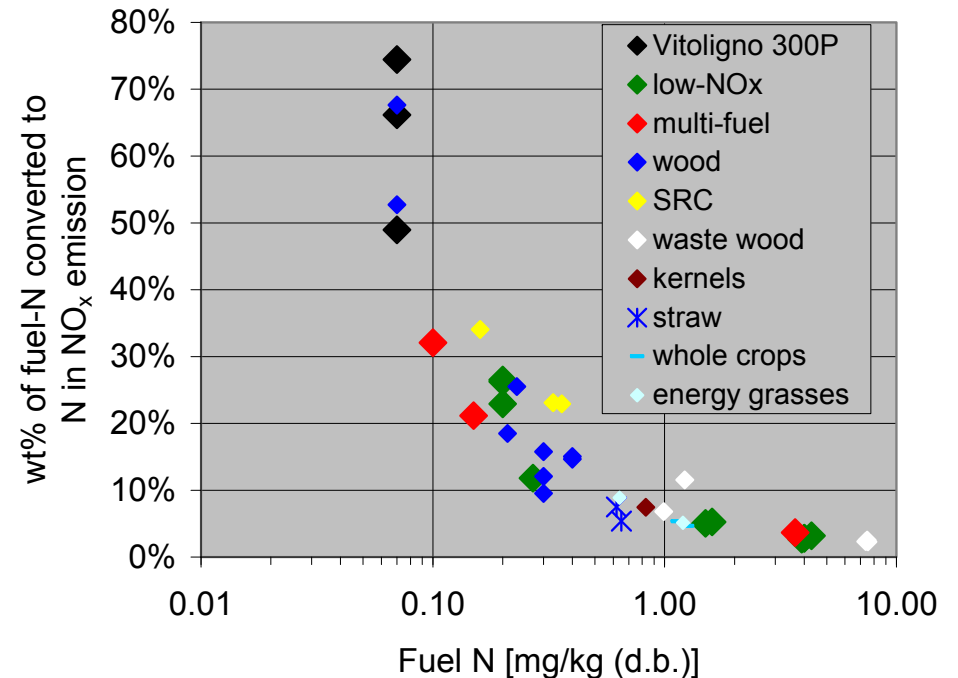
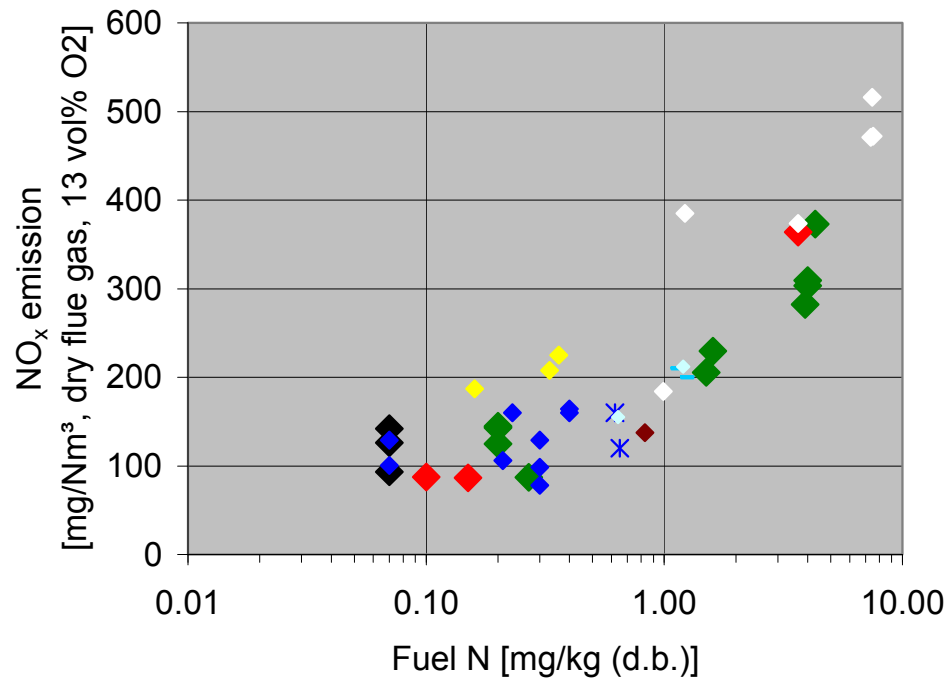



## Summary (XX) – aerosol (PM1) emissions vs. fuel composition

Results from various measurements performed at biomass grate combustion plants equipped with air staging

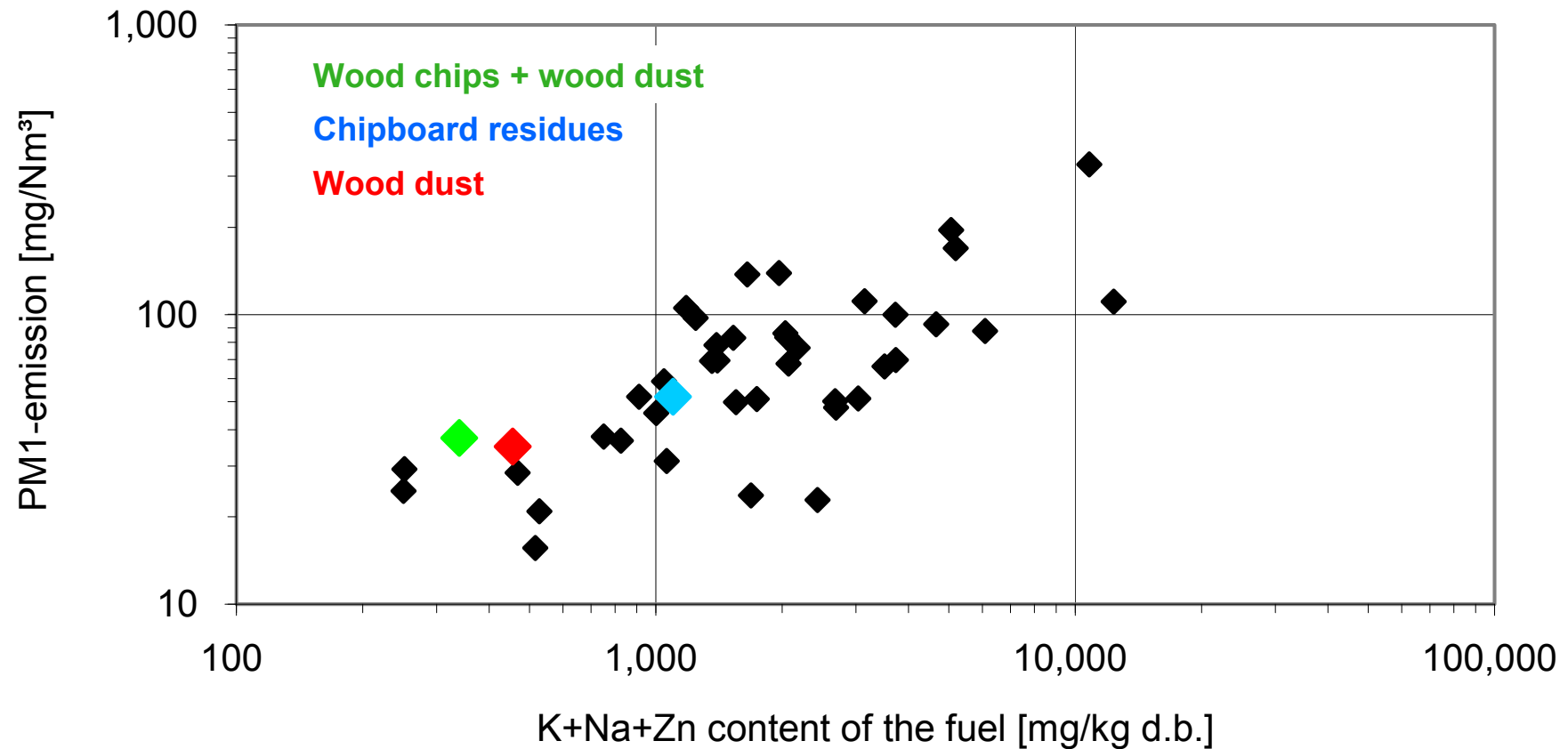



## Summary (XXI) – conclusions

### ■ Conclusions regarding NO<sub>x</sub> reduction by air staging

- Austrian research results indicate that for a minimum NO<sub>x</sub> emissions an optimum  $\lambda_{\text{primary}}$  in the range between 0.7 and 0.9, a minimal residence time in the primary combustion zone of 0.5 s and a minimal temperature in the primary combustion zone of 800°C was identified (residence time had a clear and temperature in the primary zone no relevant influence on the NO<sub>x</sub> emissions).
- CFD simulations performed showed a good agreement of simulated and measured NO<sub>x</sub> emissions. A clear reduction of NO<sub>x</sub> emissions with decreasing primary and total air ratios was identified. Furthermore, flue gas recirculation in the primary combustion zone leads to an effective mixing and a good temperature control in the zone
- Swedish research results indicate that the air ratio in the primary zone should be between 0.4 and 0.8, the temperature between 900 and 1,100 °C and the residence time in the primary zone about 0.3 s
- According to research performed by [Nussbaumer, et.al.] the respective values should be:  $\lambda_{\text{primary}}$ : 0.6 to 0.8; residence time in the primary combustion zone: >0.3 – 0.5 s and temperature in the primary combustion zone: 1,100 – 1,200°C
- In all studies presented false air was not considered
- According to Nussbaumer, et.al. flue gas recirculation had no significant influence on NO<sub>x</sub> emissions





## Summary (XXII) – conclusions

### ■ Conclusions regarding PM reduction by air staging

#### ■ Reduction of inorganic particles

- Research results from Finland indicate that air staging has a large effect on PM1 emissions (reduction from approx. 15 mg/MJ to 3 mg/MJ achieved). In addition, the counter-draft gasification technology examined achieved very low PM1 emission (1.3-2.4 mg/MJ)
- According to Nussbaumer, et.al. TSP emissions can be reduced by a factor 5 by applying low primary air ratios
- Swedish results show that the formation of submicron fly ash particles increases at increasing combustion temperatures (by a factor of approx. 2 from 700 to 950 °C).
- In addition, according to Swedish results particle concentration were reduced from 20.8 mg/Nm<sup>3</sup> to 14.8 mg/Nm<sup>3</sup> by optimising the concept of a small-scale pellet stove. However, the particle reduction is probably strongly connected to a reduction of soot

#### ■ Reduction of organic particles and soot (Swedish results derived from stove tests)

- The “soot” particle concentration (carbon content) is significantly affected by the air distribution in the combustion chamber
- For the tested stove (Pitekaminen), both the soot particle and the fly ash particle concentrations were significantly affected by the air flow rate through the grate
- The “soot” particle concentration is significantly reduced when the window was insulated
- In general, appropriate air staging, the provision of an intensive mixing of the combustion air and the flue gases in the secondary combustion zone, enough residence time in the secondary combustion zone at temperature >800°C contribute to a reduction of organic particles and soot



## Summary (XXIII) – conclusions

- **General remarks regarding residential heating boilers:**
  - **Limited data/research available**
  - **Primary combustion chambers in residential heating boilers are often too small (short residence time) for an efficient NO<sub>x</sub> reduction**
  - **False air (especially from the fuel feeding system) often significantly influences the primary air ratio and enhances strain formation (incomplete mixing) but has not yet been investigated**
  - **Better air staging concepts at partial load operation needed**
  - **Present process control systems do not actively control the air staging applied**



## Summary (XXVI) – conclusions

- **General remarks regarding medium sized fire-tube boilers:**
  - Only limited data from research projects are available
  - An evaluation and minimisation of the false air intake is important
  - An air staging control for all load conditions is relevant
  - In present medium-scale furnace and boiler concepts in most cases air staging is applied but not optimised which is due to lack of information regarding the correct application of air staging
  - The influence of flue gas recirculation and temperature control in the primary combustion chamber on  $\text{NO}_x$  reduction is insufficiently investigated
  - Therefore, the full potentials of air staging as an efficient emission reduction measure are still not used. Weak points and possible optimisations:
    - No systematic approaches for adjusting and optimising the primary air ratios with respect to the actual state of the combustion process (load, fuel quality etc.) have been implemented so far
    - No attempts for the utilisation of air staging as a measure to reduce the release of ash forming elements from the fuel bed have so far been performed
- **CFD simulations implementing detailed  $\text{NO}_x$  chemistry can strongly support an optimised design of Low  $\text{NO}_x$  combustion plants**



# Summary and Evaluation of Existing Data on Air Staging Strategies in Austria

**Country report**

**Prepared by BIOENERGY 2020+ GmbH**

**Project ERA-NET "Future BioTec"**



## Air Staging Strategies in Austria - overview over the technologies investigated

- **Automated residential heating boilers (pellets, logwood and wood chips, up to 100 kW<sub>th</sub>)**
  - **Pellet boiler technology**
- **Medium sized fire-tube boilers (up to 20 MW)**
  - **Low-NO<sub>x</sub> pilot-scale combustion plant**
  - **Multi-fuel-/low-dust combustion technology**
- **Water tube steam boilers (up to 20 MW)**
  - **No reliable data from this category available**



## Air staging strategies for residential heating boilers – residential pellet boiler – description of technology I

### ■ Basic data

- Name of technology: Vitoligno 300P
- Manufacturer: Viessmann

### ■ Basic information about the combustion concept

- Nominal boiler capacity range in kW<sub>th</sub>: 12, 18 and 24 kW
- Fuels used: softwood pellets
- Boiler technology: fire-tube boiler
- Fuel feeding system: rotary feeder and screw conveyor



## Air staging strategies for residential heating boilers – residential pellet boiler – description of technology II

- **Basic information about the combustion concept (continued)**
  - **Burner and grate technology:**
    - overfeed burner system
    - grate (is rotated for ash removal every 12 hours)
  - **Geometry of the furnace:**
    - separated primary and secondary combustion chamber (primary combustion chamber is very small, see picture)
  - **Furnace materials and insulation:**
    - primary combustion chamber: insulated with schamotte
    - secondary combustion chamber: partly insulated with schamotte and partly cooled with water jacket



## Air staging strategies for residential heating boilers – residential pellet boiler – description of technology III

- **Basic information about the combustion concept (continued)**
  - **General description of the control strategy:**
    - **Load control:**
      - controlled variable: water temperature at boiler outlet
      - manipulated variable: amount of fuel and speed of the flue gas fan
    - **Combustion control:**
      - controlled variable: O<sub>2</sub> content in the flue gas
      - manipulated variable: secondary air valves
    - **Furnace temperature:**
      - controlled variable: temperature in the secondary comb. zone
      - manipulated variable: fine adjustment of the fuel feed
  - **Partial load behaviour:**
    - continuous operation at 30 – 100% of nominal load possible





## Air staging strategies for residential heating boilers – residential pellet boiler – description of technology IV

- **Basic information concerning the air staging strategy applied**
  - **Combustion air distribution concept**
    - Primary air injected below the grate and
    - secondary air slightly above the fuel bed via secondary air nozzles
  - **Geometric concept of the furnace with respect to air staging**
    - since secondary air is directly injected above the fuel bed no efficient air staging concept regarding  $\text{NO}_x$  reduction exists
  - **Flue gas recirculation**
    - no flue gas recirculation applied



## Air staging strategies for residential heating boilers – residential pellet boiler – description of technology V

- **Basic information concerning the air staging strategy applied**
  - **Flexibility concerning air staging and air distribution setup**
    - control of primary and secondary air flow by valves allows efficient air staging and flexible air ratios
    - however, air staging is not effective since the secondary air is injected slightly above the fuel bed and the primary combustion chamber is thus quite small
  - **Combustion air and air distribution controls applied**
    - primary and secondary air flows are controlled by valves
    - parameterization of the position of the primary air valve and the O<sub>2</sub> content in the flue gas for full and 30% load possible
    - no measurement systems for air flow are implemented
    - no efficient air staging strategy implemented, since the primary combustion chamber is too small



## Air staging strategies for residential heating boilers – residential pellet boiler – pictures/schemes of technology

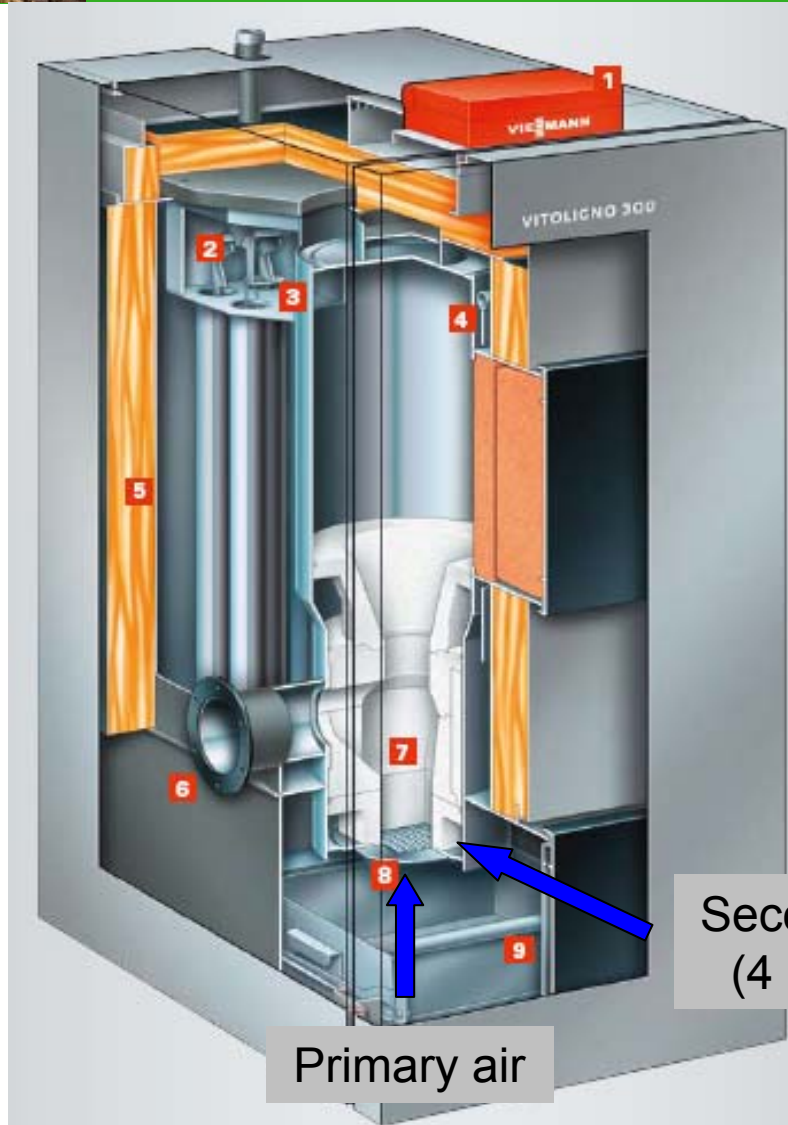

- 1 Control panel
- 2 Automatic heat exchanger cleaning system
- 3 Metal jacket (cooled)
- 4 Internal pre-heating of the return
- 5 Insulation
- 6 Fuel feeding
- 7 Secondary combustion chamber
- 8 Fin grate
- 9 Ash tray

Secondary air  
(4 nozzles)

Primary air



## Air staging strategies for residential heating boilers – residential pellet boiler – pictures/schemes of technology

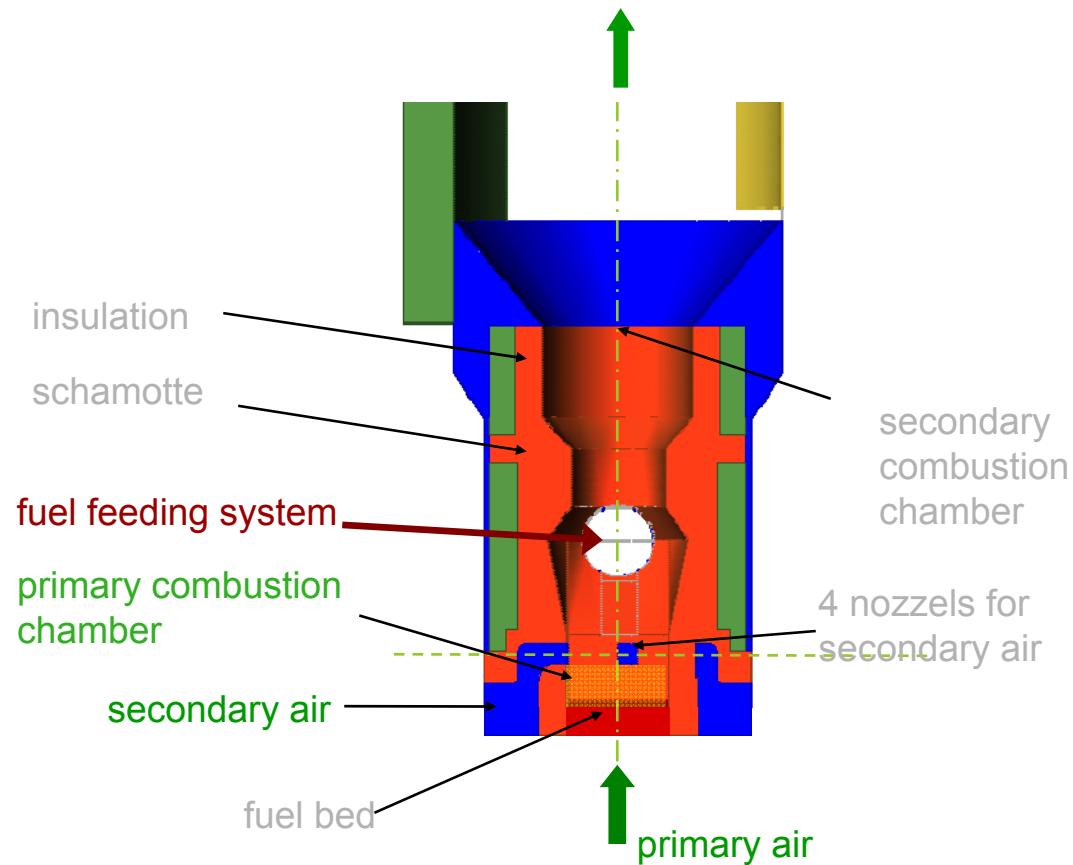



## Air staging strategies for residential heating boilers – research performed on residential pellet boiler - objectives

- **Objectives of the research work performed**
  - **Measurement of the gaseous and particulate emissions at full load (24 kW), at 18 kW and at approx. 4 kW load (= 30% load of 12 kW nominal boiler capacity)**
  - **Determination of the primary and secondary combustion air flows in order to calculate the primary and total air ratio**



## Research performed on residential pellet boiler – picture of the test stand (1)

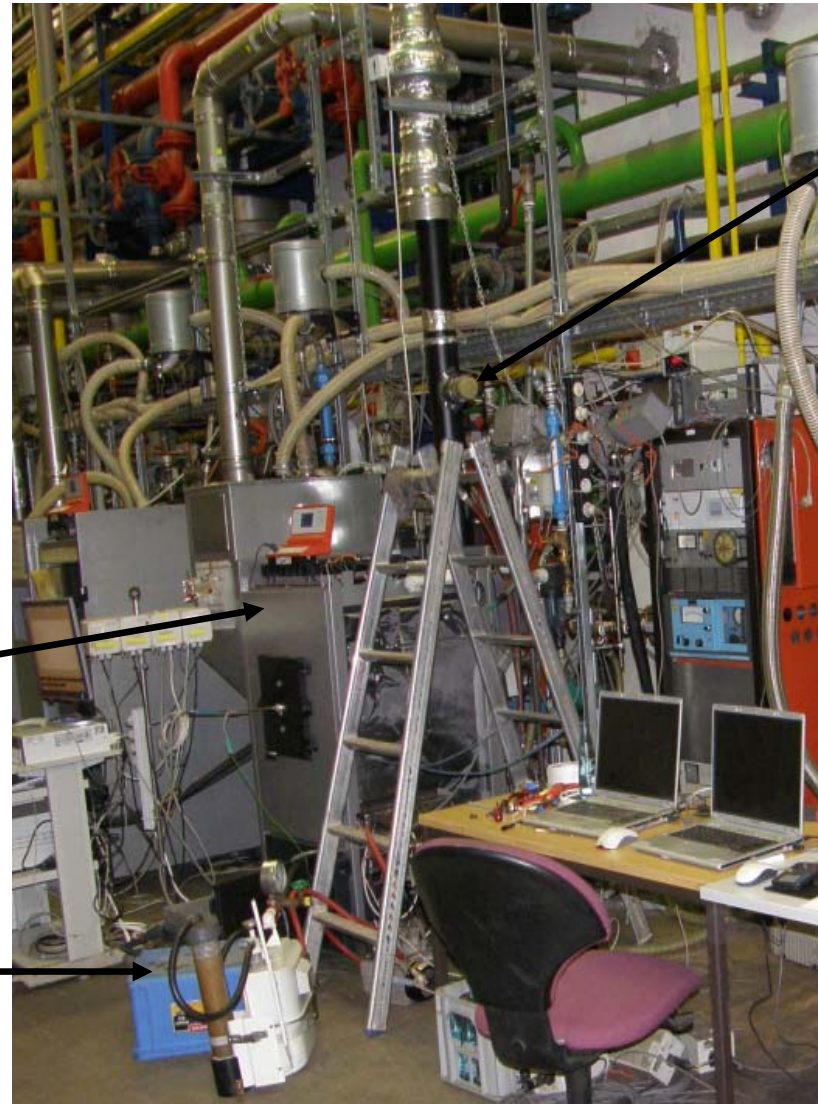

**Vitoligno 300P**

**Equipment  
for total dust  
measurement**

**Total dust  
and aerosol  
measurement**

**Measurement  
device for  
gaseous  
emissions**



Research performed on residential pellet boiler –  
picture of the test stand (2) – air velocity measurements

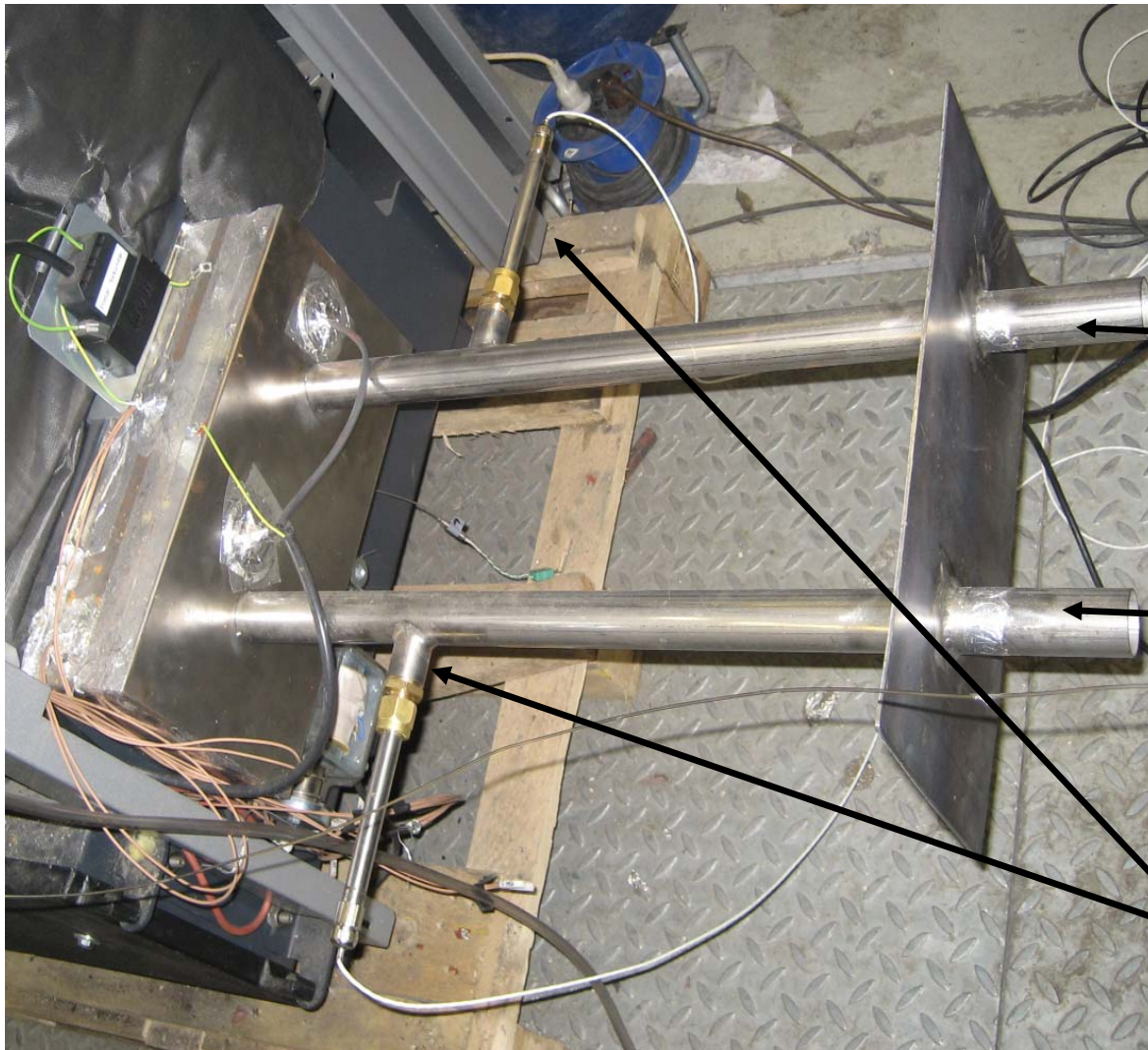

Secondary air

Primary air

Flow sensors



## Research performed on residential pellet boiler – Methodology applied (I)

### ■ Gaseous emissions

Measured variable	device	principle	range
O <sub>2</sub> content in the flue gas	ABB EL 3020	Paramagnetism	0 - 21,5 Vol%
CO content in the flue gas	Maihak UNOR 6N	Infrared absorption	0 - 10.000 ppm
NO <sub>x</sub> content in the flue gas	Beckman Industrial 951A	Chemical luminescence	0 - 1.000 ppm

### ■ Particulate and dust measurement

Measured variable	device	principle	range
PM <sub>1</sub> emissions discontinuous	Low-pressure Berner - type impactor (BLPI)	Impaction	0,0625- 16 µm (ae.d.)
PM <sub>1</sub> emissions continuous	Electric low-pressure impactor (ELPI)	Impaction	0,03 - 9,97 µm (ae.d.)
Total dust	Filter (according to VDI 2066)	Isokinetic sampling, filtration	





## Research performed on residential pellet boiler – Methodology applied (II)

### ■ Plant parameters

Measured variable	device	principle	range
Flue gas temperatures	Themocouple (Typ K)	Thermo-electric voltage	-250 - 1.372°C
Primary and secondary air velocity	Schmid SS20	Velocity measurement based on heat transfer	0 - 20 m/s



# Research performed on residential pellet boiler – Example for data from measurements performed

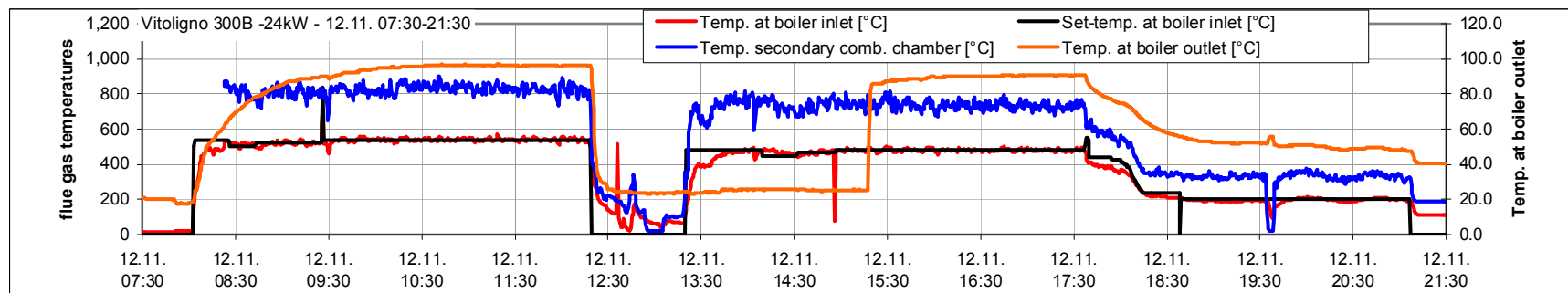
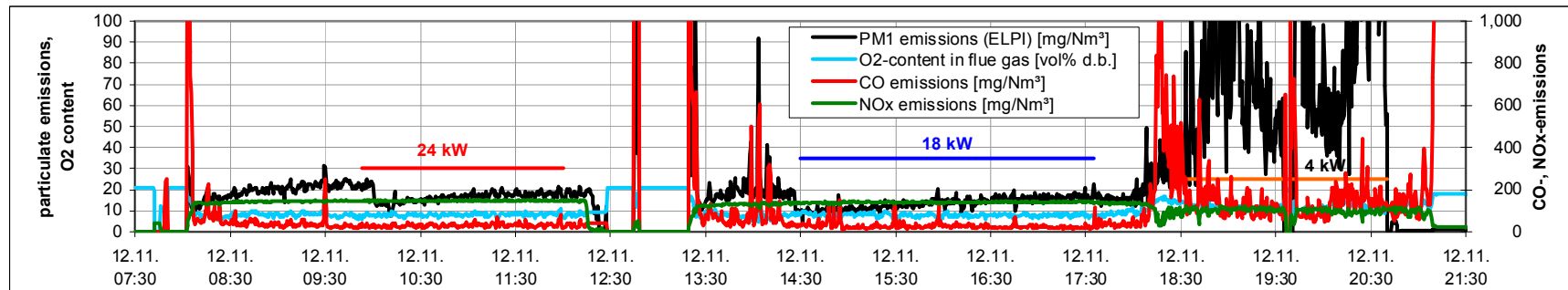
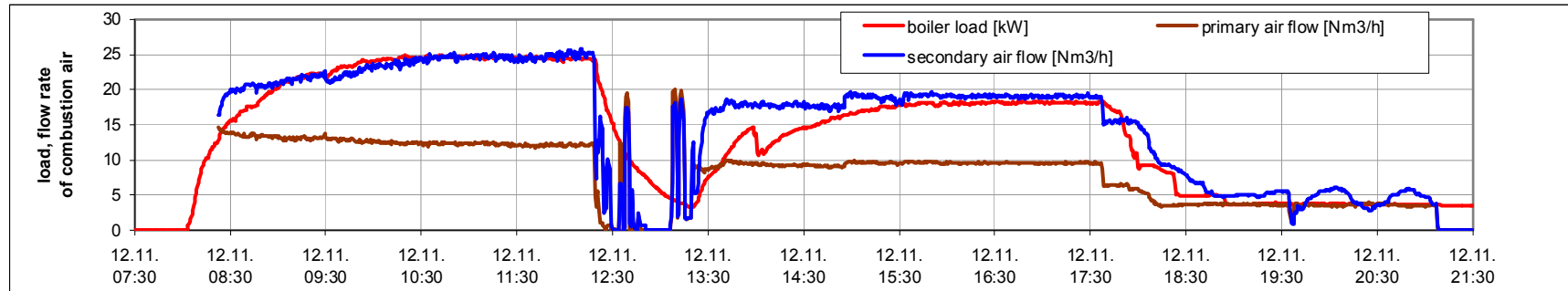



## Research performed on residential pellet boiler – emissions and efficiency

<b>boiler load</b>	<b>[kW]</b>	<b>24.2</b>	<b>17.5</b>	<b>3.6</b>
thermal efficiency	[%]	91.8	91.2	81.5
O <sub>2</sub> content in the flue gas	[Vol% fg d.b.]	8.0	7.9	12.2
primary air ratio	[-]	0.43 - 0.58	0.54	1.01
total air ratio	[-]	1.59 - 1.65	1.61	2.35
CO emissions	[mg/MJ]	22.2	18.3	104.4
standard deviation		10.7	10.8	86.2
OGC emissions	[mg/MJ]	<0.7	<0.7	<1.3
NO <sub>x</sub> emissions	[mg/MJ]	94.7	84.2	62.3
standard deviation		1.6	1.8	8.4
total dust emissions	[mg/MJ]	15.3	8.9	55.1
range	[mg/MJ]	(11.5-24.0)	(8.6-9.3)	(-)
number of measurements	[-]	4	2	1
PM1 emissions (ELPI)	[mg/MJ]	10.0	9.1	53.9
PM1 emissions (BLPI)	[mg/MJ]	9.1	10.5	50.1
range	[mg/MJ]	(8.4-10.1)	(14.8-16.6)	(-)
number of measurements	[-]	3	2	1

Remarks: fg ... flue gas, ELPI measurements calibrated with BLPI,  
[mg/MJ] ... [mg/Nm<sup>3</sup> dry flue gas 13vol%O<sub>2</sub>]/1.5



## Research performed on residential pellet boiler – NO<sub>x</sub>, CO and dust emissions versus boiler load

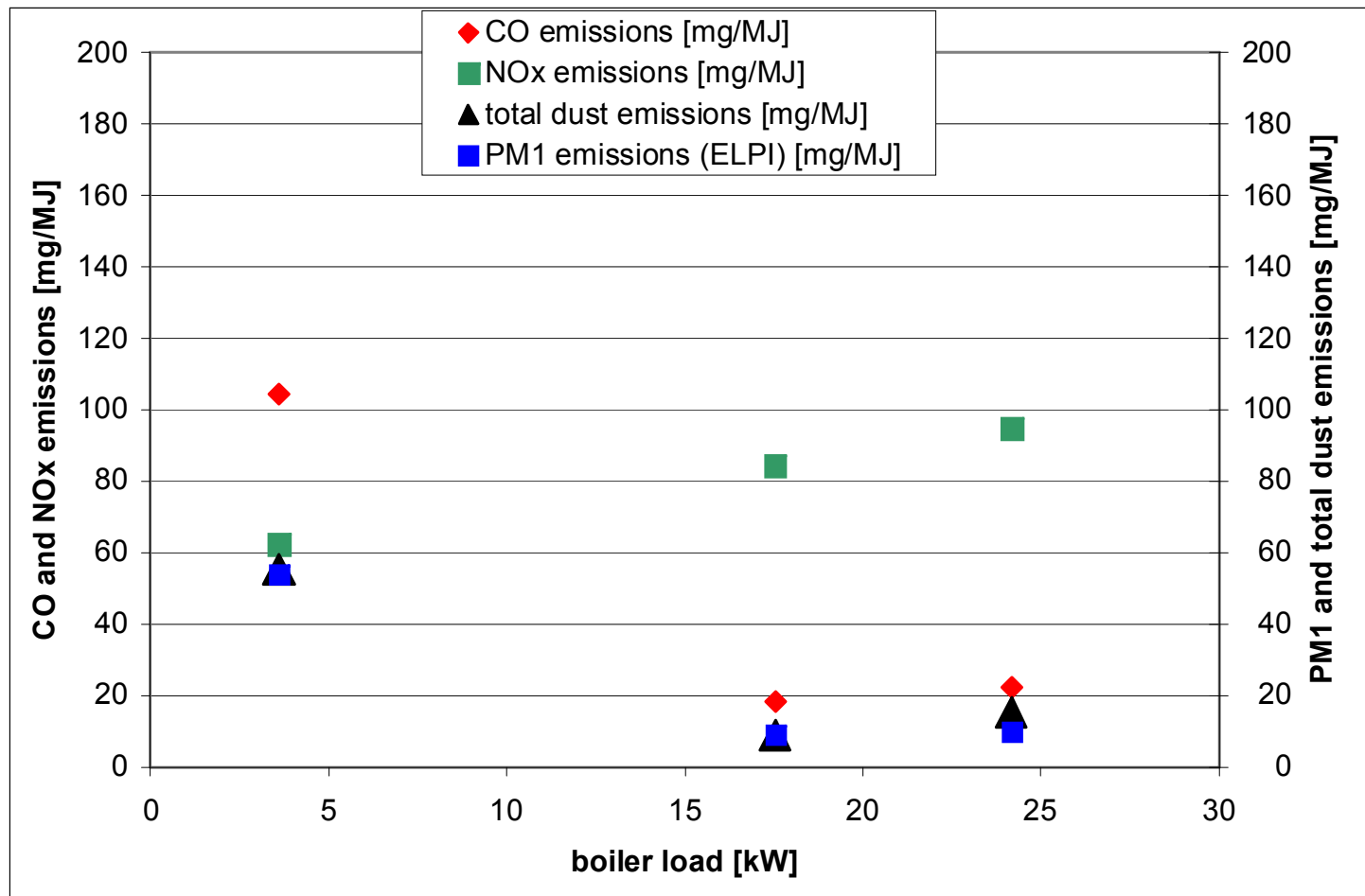

Remarks: [mg/MJ] ... [mg/Nm<sup>3</sup> dry flue gas 13vol%O<sub>2</sub>]/1.5



## Research performed on residential pellet boiler – PM<sub>1</sub> emissions versus total dust emissions

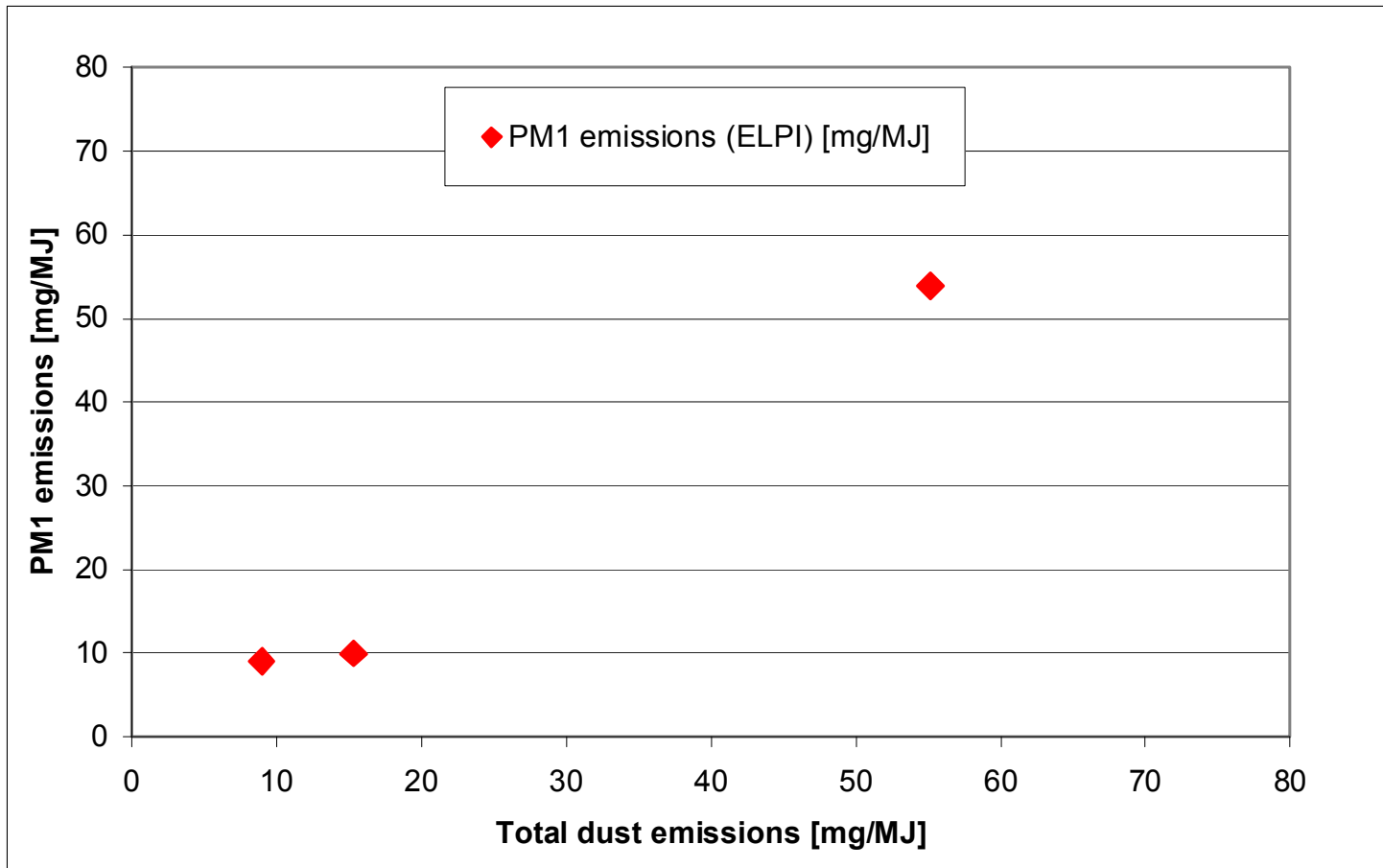

Remarks: [mg/MJ] ... [mg/Nm<sup>3</sup> dry flue gas 13vol%O<sub>2</sub>]/1.5



Research performed on residential pellet boiler – fuel N converted to NO<sub>x</sub> in dependence of the N content in the fuel

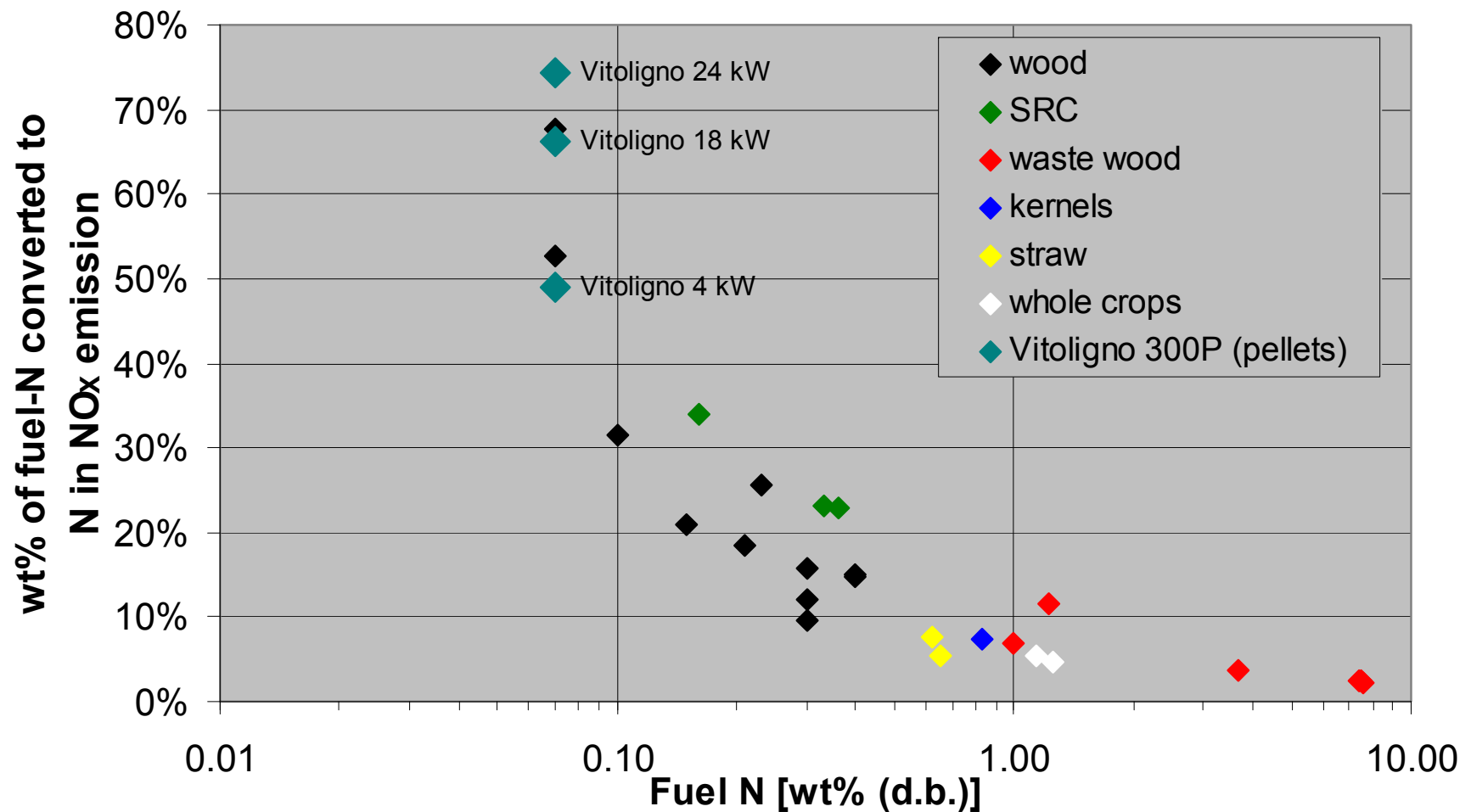



## Air staging strategies for residential heating boilers – residential pellet boiler – evaluation of the technology I

### ■ False air measurements/calculations

- Not performed within the scope of the measurements presented
- Other measurements performed at the Vitoligno 300P showed that the false air amounts to approx. 20 – 40% of the total air amount (at full load)
- Main sources: fuel feeding system (approx. 12%) and ignition system (approx. 10%)

### ■ How is air staging implemented within the concept?

- Since the secondary air nozzles are placed directly above the fuel bed air staging is not efficiently realised.
- The residence time of the flue gases in the primary combustion chamber is around 0.01s (according to CFD calculations performed).
- Consequently, the resulting NO<sub>x</sub> emissions are relatively high (approx. 140 mg/Nm<sup>3</sup> at full load) → optimisation potentials exist



## Air staging strategies for residential heating boiler – residential pellet boiler – evaluation of the technology II

- **Does the control concept support the air staging concept by an appropriate control of the air flows/flue gas recirculation during different combustion / load phases?**
  - **Basically the control concept would support an efficient air staging concept (2 valves for the control of the amount of combustion air available)**
  - **Parameterisation for full load and 30% load possible**
- **Does the concept also appropriately work at partial load?**
  - **Basically, it is possible to adjust the primary and total air ratio in dependence on the load.**
  - **Within the scope of the measurements performed, it was observed that the primary and total air ratio at partial load are rather high**





## Air staging strategies for residential heating boiler – Pellet boiler technology 1 – evaluation of the technology III

### ■ Conclusions regarding the research performed

- Gaseous and particulate emissions at 24 and 18 kW load are at comparable levels of state-of-the-art pellet boilers
- NO<sub>x</sub> emissions are at a comparatively high level at full load (compared to state-of-the-art pellet boilers)
- At 3.6 kW load considerable formation of soot and tar occurs. Particulate emissions are above 50 mg/MJ
- CO emissions also considerably increase at 3.6 kW compared to full load

### ■ Potentials for optimisation

- Optimization of the position of the secondary air inlets in order to increase the size of the primary combustion chamber should lead to a considerable reduction potential regarding NO<sub>x</sub> emissions



## Air staging strategies for residential heating boilers – general remarks I

- Up to now only limited data/research regarding variations of the amount of primary air (air staging studies) for residential heating boilers exist
- Most common problems:
  - Usually, no defined air staging strategy is applied
  - Primary combustion chamber is often too small
    - e.g. secondary air injection directly above the fuel bed
    - residence time too small for efficient  $\text{NO}_x$  reduction (especially at nominal load)



## Air staging strategies for residential heating boiler – general remarks II

### ■ Most common problems (continued)

- False air occurs from
  - the fuel feeding system,
  - cleaning doors and
  - the ignition system.
- False air (e.g. from fuel feeding system) increases the primary air ratio. False air is not efficiently mixed with flue gas (formation of strains).
- Secondary air backflow in the primary combustion zone results in increased  $\lambda_{\text{primary}}$   
→ CFD simulation relevant for optimisation
- False air detection is of relevance and should be considered in air staging studies.



## Air staging strategies for medium sized fire-tube boilers – low-NO<sub>x</sub> pilot-scale combustion plant – description of technology I

### ■ Basic data

- **Name of technology:** Low-NO<sub>x</sub> pilot-scale combustion plant
- **Manufacturer:** MAWERA Holzfeuerungsanlagen
- **2 plant concepts with the same furnace geometry but one based on a travelling grate (plant I) and one based on a horizontally moving grate (plant II) have been investigated**

### ■ Basic information about the combustion concept

- **Nominal boiler capacity range in kW<sub>th</sub>:** plant I: 440 kW<sub>th</sub>  
plant II: 440 kW<sub>th</sub>
- **Fuels used:** wood chips, waste wood, chipboard residues
- **Boiler technology:** fire tube boiler
- **Fuel feeding system:** screw conveyor (plant I)  
hydraulic stoker (plant II)



## Air staging strategies for medium sized fire-tube boilers – low-NO<sub>x</sub> pilot-scale combustion plant – description of technology II

- **Basic information about the combustion concept (continued)**
  - **Grate technology:**
    - travelling grate, counter-current flow (plant I)
    - horizontally moving grate with two separately controllable zones concerning grate movement, counter-current flow (plant II)
  - **Geometry of the furnace (both plants):**
    - geometrically separated primary and secondary combustion chambers
    - secondary combustion chamber consisting of one or two horizontal ducts
  - **Furnace materials and insulation (both plants):**
    - insulated furnace walls



## Air staging strategies for medium sized fire-tube boilers – low-NO<sub>x</sub> pilot-scale combustion plant – description of technology III

### ■ Basic information about the combustion concept (continued)

#### ■ General description of the control strategy (both plants):

##### – load control:

controlled variable: feed temperature

manipulated variables: fuel supply, primary air supply

##### – combustion control:

controlled variable: O<sub>2</sub> content of the flue gas

manipulated variable: secondary air supply

##### – furnace temperature:

controlled variable: temp. in the secondary combustion zone

manipulated variable: flue gas recirculation above the grate  
(the flue gas recirculation below the grate is manually controlled and usually set to a constant value)

#### ■ Partial load behaviour:

continuous operation at 30 – 100% of nominal load possible



## Air staging strategies for medium sized fire-tube boilers – low-NO<sub>x</sub> pilot-scale combustion plant – description of technology IV

- **Basic information concerning the air staging strategy applied**
  - **Combustion air distribution concept (both plants)**
    - **Primary combustion air** supplied below the grate in 4 separated zones with independently controllable air fans
    - Plant I: **secondary combustion air** supplied either at the beginning or at the end of the first duct of the combustion chamber (short or long reducing zone can be achieved)  
Plant II: **secondary combustion air** supplied at the end of the first duct of the combustion chamber
  - **Geometric concept of the furnace with respect to air staging**
    - Well separated primary and secondary combustion zone (both plants)



## Air staging strategies for medium sized fire-tube boilers – low-NO<sub>x</sub> pilot-scale combustion plant – description of technology V

### ■ Basic information concerning the air staging strategy applied (continued)

#### ■ Flue gas recirculation (both plants):

- Plant I: flue gas recirculation via 1 recirculation fan (distribution controlled by valves):
  - primary combustion chamber (below the grate, above the grate)
  - secondary combustion chamber (front-side, from the side-walls)
- Plant II: flue gas recirculation via 2 recirculation fans
  - fan 1: below the grate
  - fan 2: above grate
- Flue gas recirculation ratio: <0.5; actual value depending on the set-point of the temperature control and the fuel moisture content





## Air staging strategies for medium sized fire-tube boilers – low-NO<sub>x</sub> pilot-scale combustion plant – description of technology VI

### ■ Basic information concerning the air staging strategy applied

#### ■ Flexibility concerning air staging and air distribution setup

- Generally, high flexibility regarding air staging options since the 4 primary and the secondary air fans can be controlled independently
- However, some restrictions regarding the grate technology exist. In a travelling grate system almost no mixing of the fuel takes place (as it happens on a horizontally or an inclined moving grate).
- Therefore, higher gas velocities in the fuel bed are needed to speed-up pyrolysis, gasification and combustion reactions. Consequently, the minimum demand for primary air is higher than for moving grates even if, as it was done in our case, flue gas recirculation below the grate is applied to increase gas velocities in the fuel bed.



## Air staging strategies for medium sized fire-tube boilers – low-NO<sub>x</sub> pilot-scale combustion plant – description of technology VII

### ■ Basic information concerning the air staging strategy applied (continued)

#### ■ Combustion air and air distribution controls applied

- All combustion air flows and the flue gas recirculation flows were measured with Prandtl tubes
- Determination of the air ratios:
  - total air ratio*: calculated from the oxygen content in the flue gas
  - primary air ratios*: calculated from the total air ratio as well as the volume flows of primary air and flue gas recirculation
- Air staging control:
  - Primary air supply*: by the set-points for the primary air supply below the grate with respect to the fuel supply (load control)
  - Total air ratio*: by the set-point for the oxygen content in the flue gas (combustion control)



# Air staging strategies for medium sized fire-tube boilers – low-NO<sub>x</sub> pilot-scale combustion plant – pictures/schemes of technology

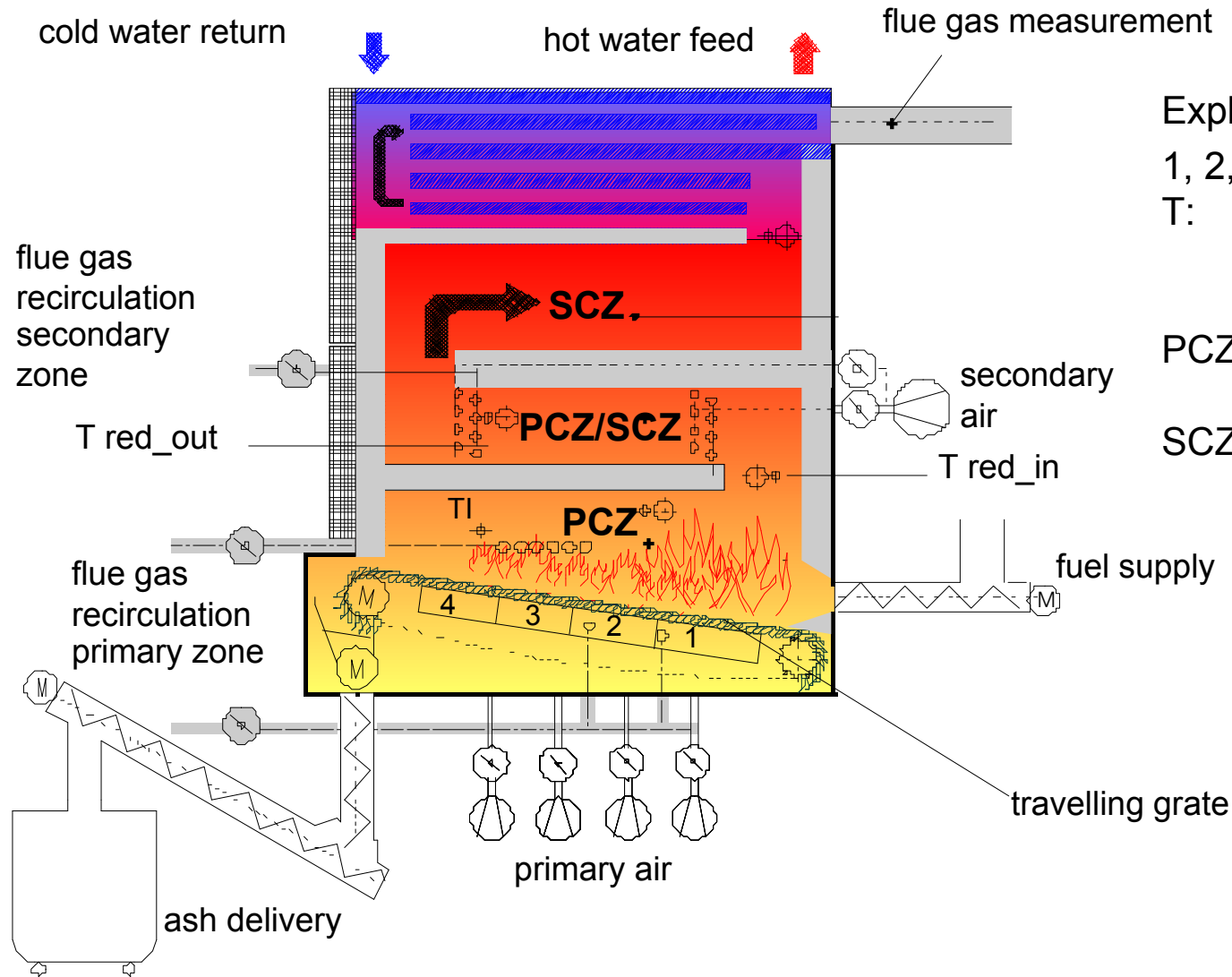

## Plant I

Explanations:

1, 2, 3, 4: grate zones

T: temperature measurement and recording

PCZ ... primary combustion zone

SCZ ... secondary combustion zone



# Air staging strategies for medium sized fire-tube boilers – low-NO<sub>x</sub> pilot-scale combustion plant – pictures/schemes of technology

Plant II

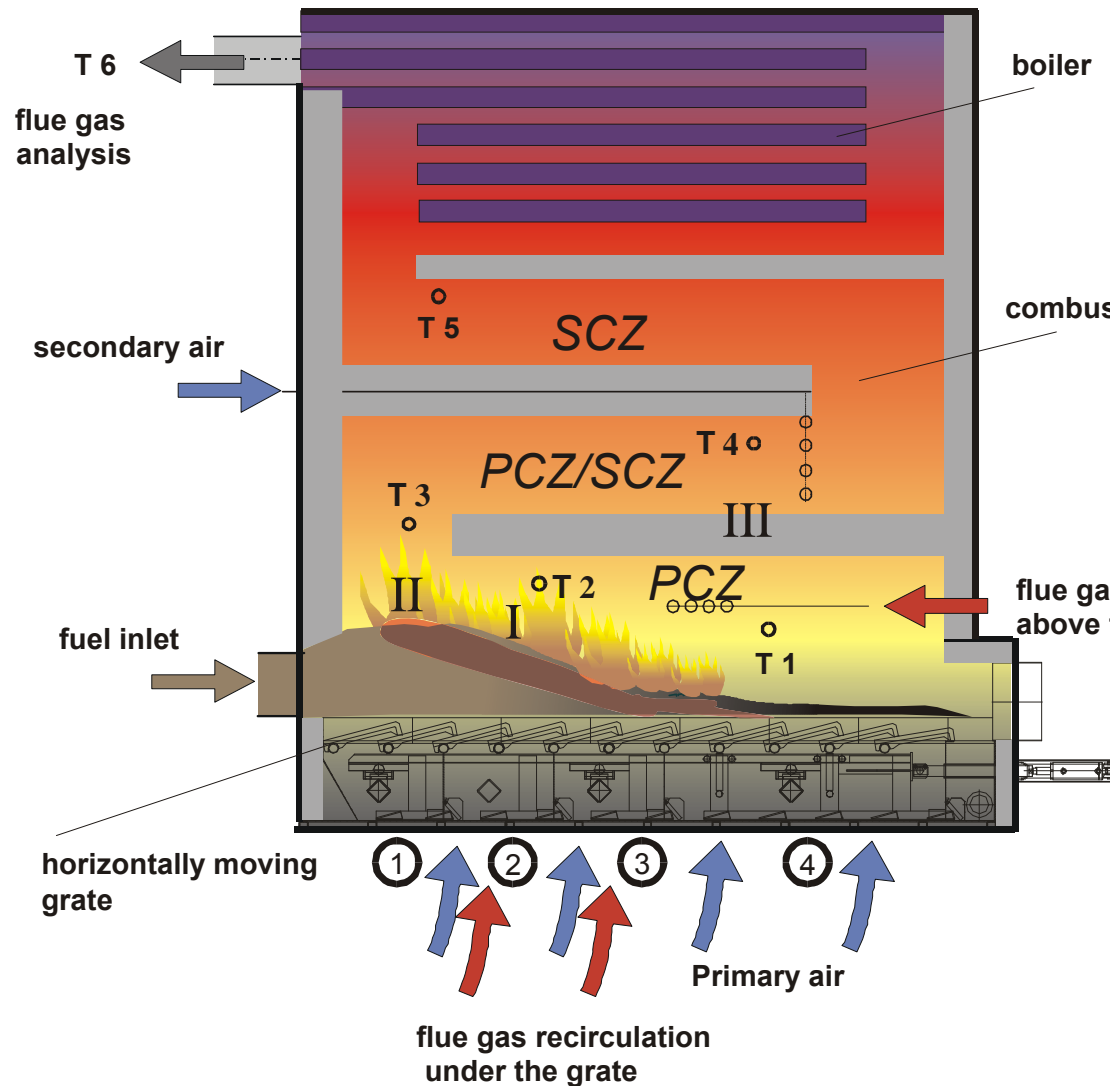

Explanations:

1, 2, 3, 4: grate zones

T1 – T6: temperature measurement and recording

PCZ ... primary combustion zone

SCZ ... secondary combustion zone



## Air staging strategies for medium sized fire-tube boilers – research performed on the low-NO<sub>x</sub> pilot-scale combustion plant

### ■ Objectives of the research work performed

- Investigation of NO<sub>x</sub> formation processes in grate-fired biomass combustion systems

### ■ Methodology applied

- Experimental investigations at pilot-scale grate-fired combustion systems regarding NO<sub>x</sub> emissions and fuel conversion
- Lab-scale tests regarding the release of NO<sub>x</sub>-precursors from the fuel during combustion
- Investigations regarding gas-phase kinetics under special consideration of NO<sub>x</sub> kinetics by simulations



## Air staging strategies for medium sized fire-tube boilers – research performed on the low-NO<sub>x</sub> pilot-scale combustion plant

### ■ Measurement equipment applied

- O<sub>2</sub>: paramagnetic sensor
- CO: ND-IR
- NO<sub>x</sub>: CLD
- Total dust: according to VDI 2006
- PM<sub>1</sub>: 9-stage Berner-type low-pressure impactor
- Velocities of combustion air and flue gas: Prandtl tubes



## Air staging strategies for medium sized fire-tube boilers – research performed on the low-NO<sub>x</sub> pilot-scale combustion plant

### ■ Results

- Results from test runs performed with woody biomass fuels with different N contents ranging between 0.2 wt% d.b. (wood chips) and 4.9 wt% d.b. (chipboard residues)
- Test runs performed at different primary air ratios
- Some relevant results are presented on the following slides
- Literature: [1], [2], [3]



## Air staging strategies for medium sized fire-tube boilers – research performed on the low-NO<sub>x</sub> pilot-scale combustion plant

### ■ Parameters

fuel		plant I						plant II			
		wood chips		waste wood		chipboard residues		wood chips		chipboard residues	
water content	[wt% (w.b.)]	40.70	41.90	16.10	16.00	8.50	7.60	37.10	40.27	10.23	10.97
ash content	[wt% (d.b.)]	1.00	0.80	8.00	9.30	1.10	1.10	1.11	0.62	1.90	1.40
C	[wt% (d.b.)]	48.00	47.90	46.10	45.80	46.40	48.80	47.53	47.90	49.30	49.60
H	[wt% (d.b.)]	6.50	6.50	6.40	6.20	6.50	6.90	6.47	6.53	5.70	5.80
N	[wt% (d.b.)]	0.20	0.20	1.60	1.50	4.00	4.30	0.27	0.20	3.90	4.00
GCV	[kJ/kg (d.b.)]	18.10	18.00	18.00	17.90	17.90	19.50	-	-	-	-
NCV	[kJ/kg (w.b.)]	19.10	19.10	18.40	18.30	18.10	19.70	-	-	-	-
boiler load	[kW]	389	410	384	402	403	420	276	324	377	403
λ <sub>prim</sub>	[-]	1.20	1.04	0.93	1.15	0.86	0.97	0.79	0.91	0.76	0.70
λ <sub>total</sub>	[-]	1.73	1.66	1.69	1.89	1.65	1.66	1.84	1.71	1.69	1.50
NO <sub>x</sub>	[mg/MJ]	95.4	96.4	153.0	137.1	206.1	248.7	58.0	83.3	202.3	188.1
CO	[mg/MJ]	10.5	1.4	3.8	3.7	6.5	6.4	10.1	6.9	5.8	4.9

Explanations: NO<sub>x</sub> calculated as NO<sub>2</sub>  
 d.b. ... dry base  
 w.b. ... wet base  
 GCV ... gross calorific value  
 NCV ... net calorific value





## Air staging strategies for medium sized fire-tube boilers – research performed on the low-NO<sub>x</sub> pilot-scale combustion plant

### ■ Plant I; results for wood chips (N-content: 0.3 wt% d.b.)

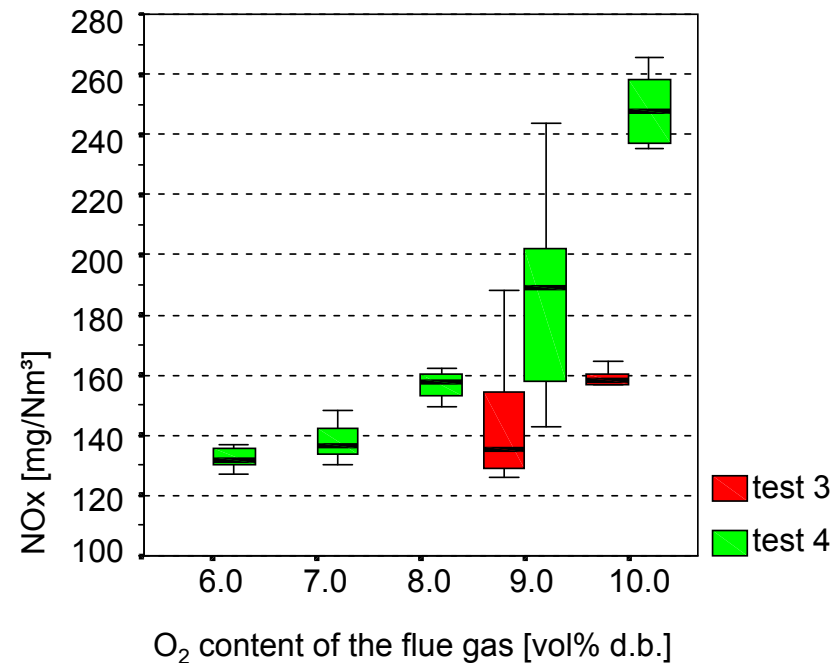
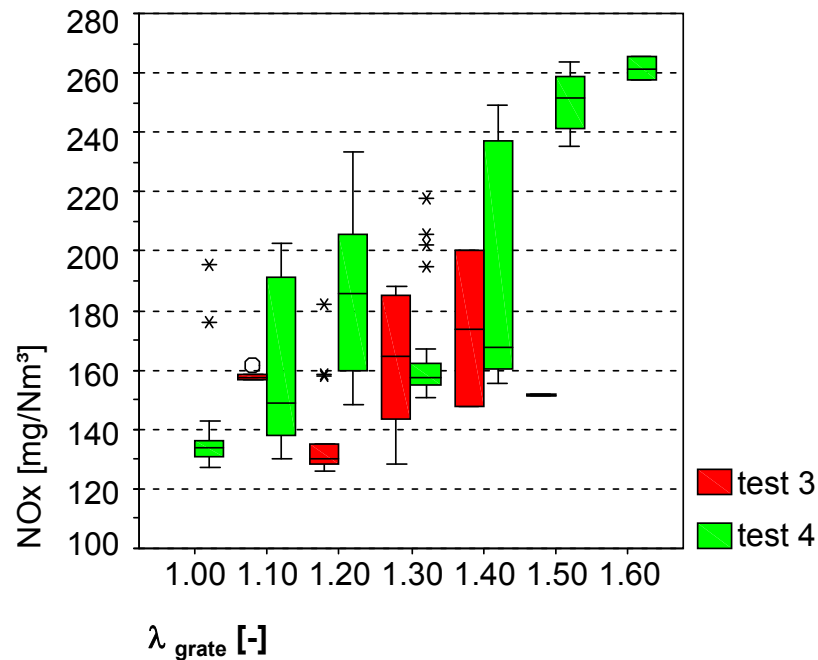

Explanations: load: 85 to 100% of the nominal capacity

fuel moisture content: 41.4 wt% w.b.

average temperature at the inlet of the reduction zone ( $T_{red\_in}$  in the plant scheme): 686 – 793°C

average residence time in the primary combustion zone: 0.5 - 0.8 s (CFD-simulation)

statistics based on 1 minute mean values; NO<sub>x</sub> calculated as NO<sub>2</sub>

NO<sub>x</sub> emission related to dry flue gas and 13 vol% O<sub>2</sub>



## Air staging strategies for medium sized fire-tube boilers – research performed on the low-NO<sub>x</sub> pilot-scale combustion plant

### ■ Plant I; results for waste wood (N-content: 0.8 – 1.8 wt% d.b.)

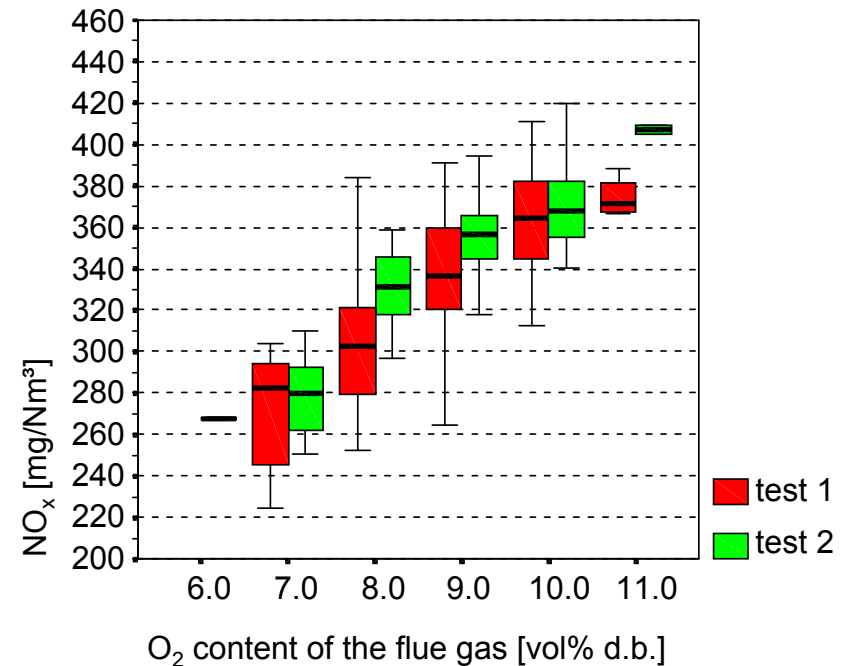
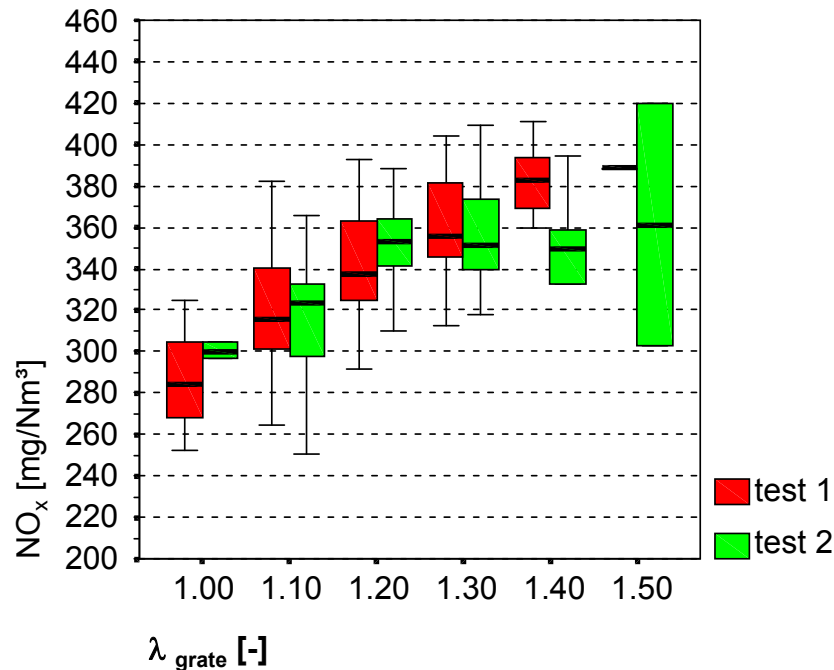

Explanations: load: 85 to 100% of the nominal capacity

fuel moisture content: 16.0 wt% w.b.

average temperature at the inlet of the reduction zone ( $T_{red\_in}$  in the plant scheme): 970 – 1,058°C

average residence time in the primary combustion zone: 0.5 - 0.8 s (CFD-simulation)

statistics based on 1 minute mean values; NO<sub>x</sub> calculated as NO<sub>2</sub>

NO<sub>x</sub> emission related to dry flue gas and 13 vol% O<sub>2</sub>



## Air staging strategies for medium sized fire-tube boilers – research performed on the low-NO<sub>x</sub> pilot-scale combustion plant

### ■ Plant I; results for chipboard residues (N-content: 3 - 4 wt% d.b.)

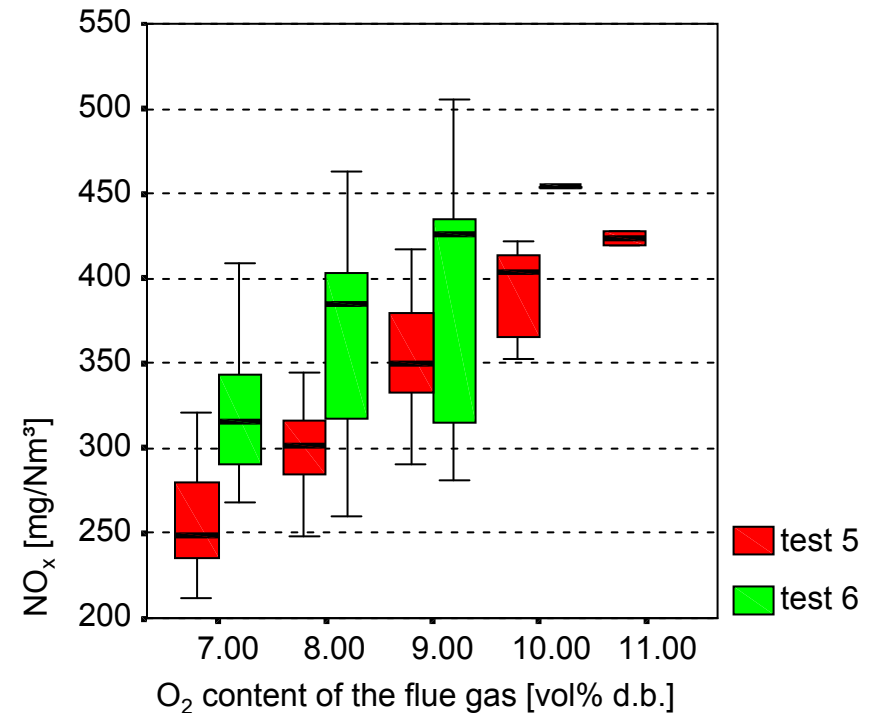
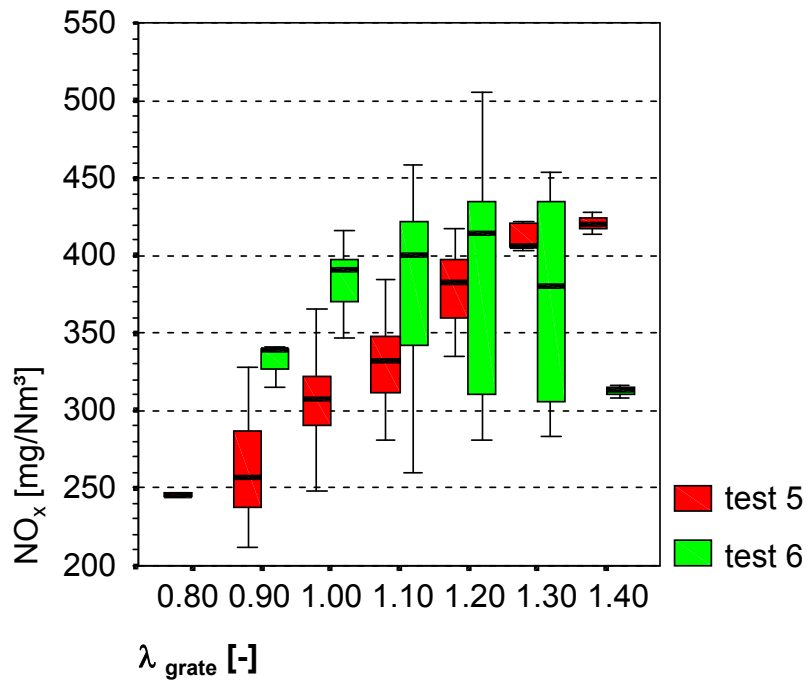

Explanations: load: 85 to 100% of the nominal capacity

fuel moisture content: 8.1 wt% w.b.

average temperature at the inlet of the reduction zone ( $T_{\text{red\_in}}$  in the plant scheme): 1,018 – 1,103°C

average hydrodynamic residence time in the primary combustion zone: 0.8 s (CFD-simulation)

statistics based on 1 minute mean values; NO<sub>x</sub> calculated as NO<sub>2</sub>

NO<sub>x</sub> emission related to dry flue gas and 13 vol% O<sub>2</sub>



## Air staging strategies for medium sized fire-tube boilers – research performed on the low-NO<sub>x</sub> pilot-scale combustion plant

### ■ Plant I; results: influence of the residence time in the primary combustion zone

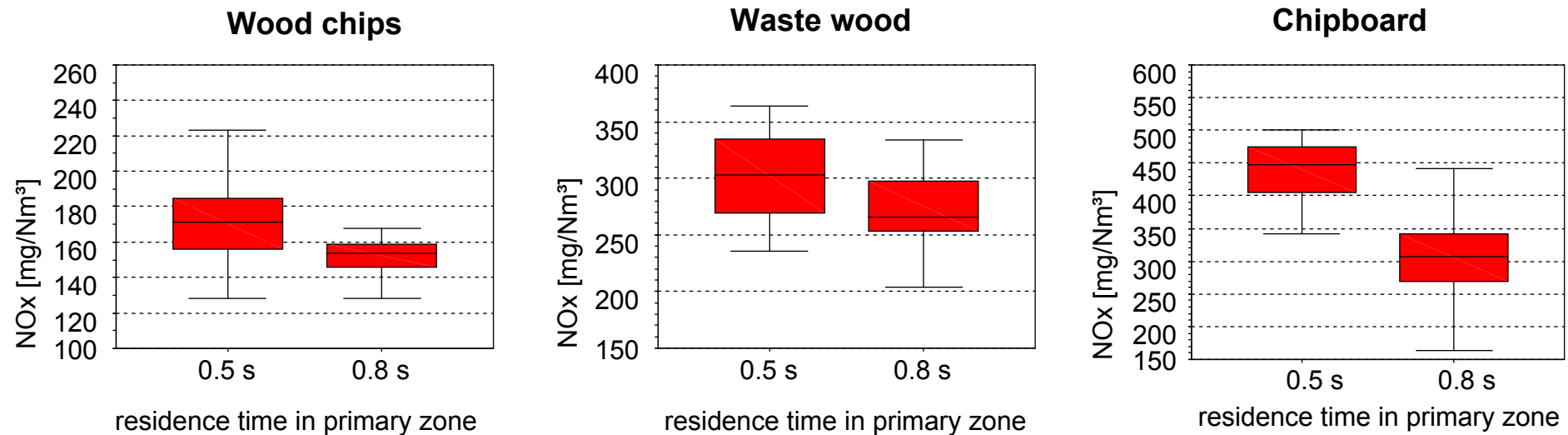

Explanations: load: 85 to 100% of the nominal capacity;  
 statistics based on 1 minute mean values; NO<sub>x</sub> calculated as NO<sub>2</sub>  
 NO<sub>x</sub> emission related to dry flue gas and 13 vol% O<sub>2</sub>



## Air staging strategies for medium sized fire-tube boilers – research performed on the low-NO<sub>x</sub> pilot-scale combustion plant

### ■ Plant II; results for chipboard residues (N-content: 3.9 wt% d.b.)

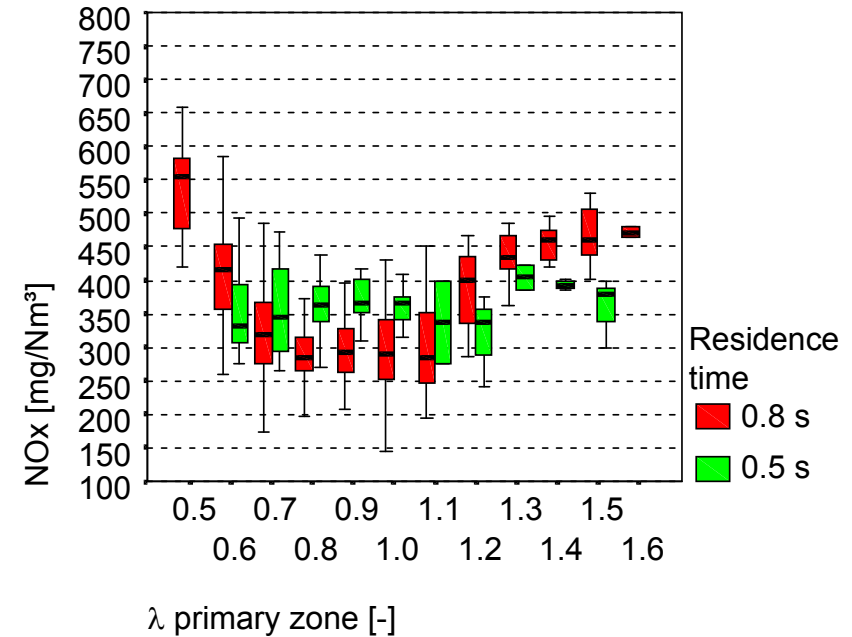
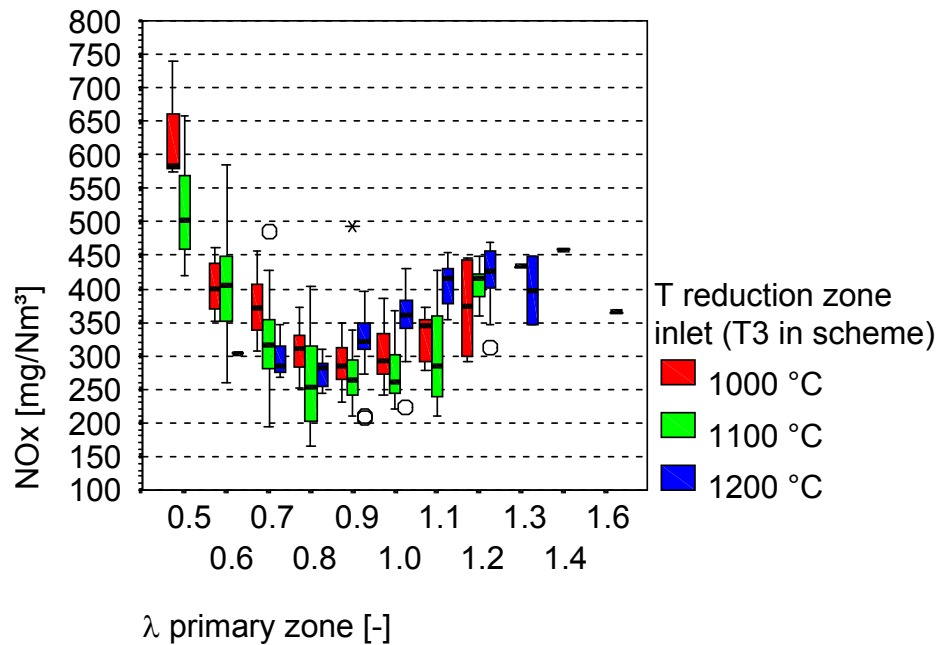

Explanations: load: 80 to 100% of the nominal capacity  
 fuel moisture content: 10.6 wt% w.b.  
 left diagram: residence time in the primary combustion zone: 0.8 s  
 statistics based on 1 minute mean values; NO<sub>x</sub> calculated as NO<sub>2</sub>  
 NO<sub>x</sub> emission related to dry flue gas and 13 vol% O<sub>2</sub>



## Air staging strategies for medium sized fire-tube boilers – research performed on the low-NO<sub>x</sub> pilot-scale combustion plant

### ■ Plant I+II; summary of results

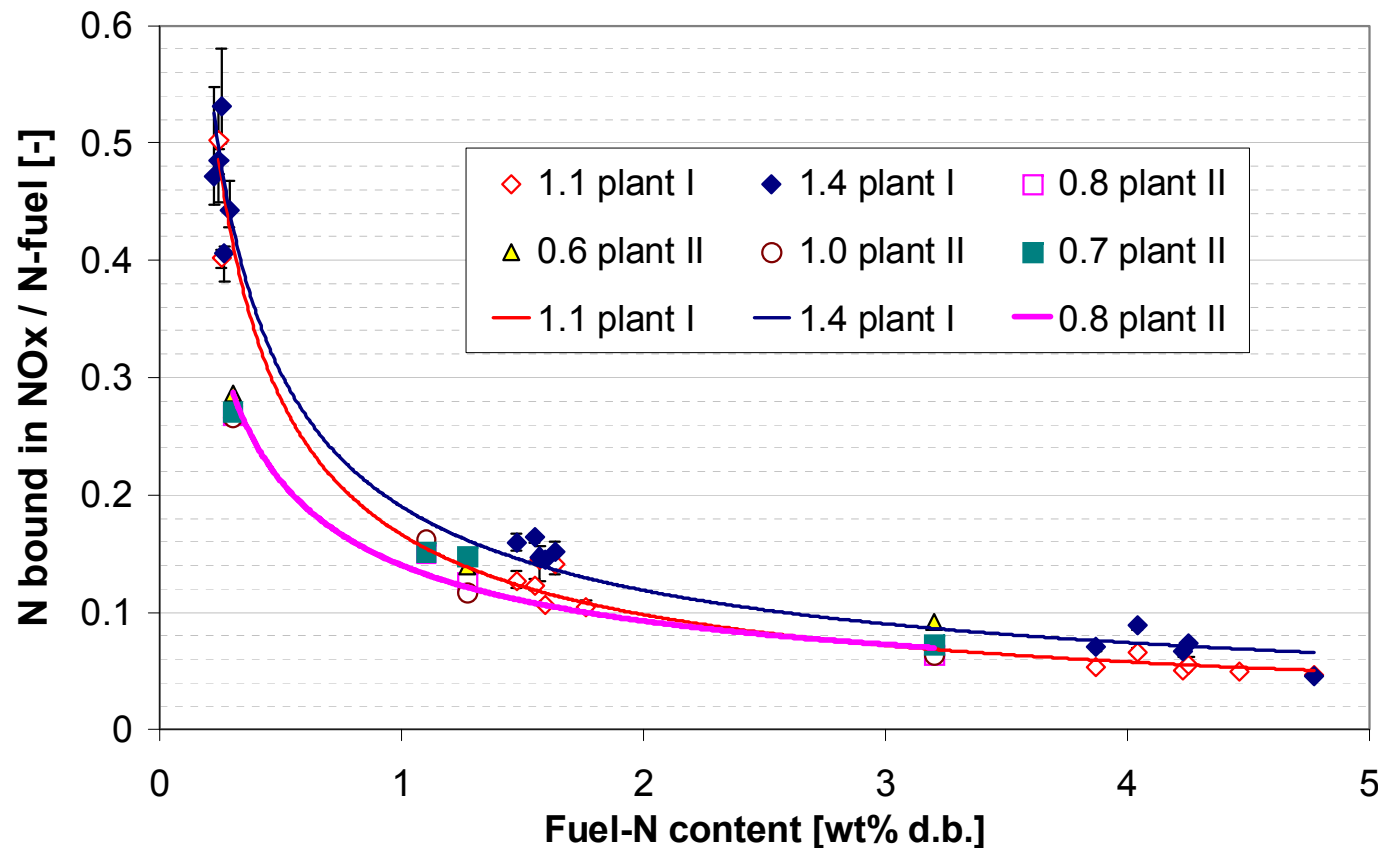

Explanations: Degree of conversion of fuel-N to NO<sub>x</sub> at the plants investigated for different primary air ratios (0.8-1.4) resulting in trend lines for different primary air ratios (0.8, 1.1, 1.4); load: 80 to 100% of the nominal capacity; residence time in the primary combustion zone: 0.5 - 0.8s



## Air staging strategies for medium sized fire-tube boilers – research performed on the low-NO<sub>x</sub> pilot-scale combustion plant

### ■ Comparison with literature

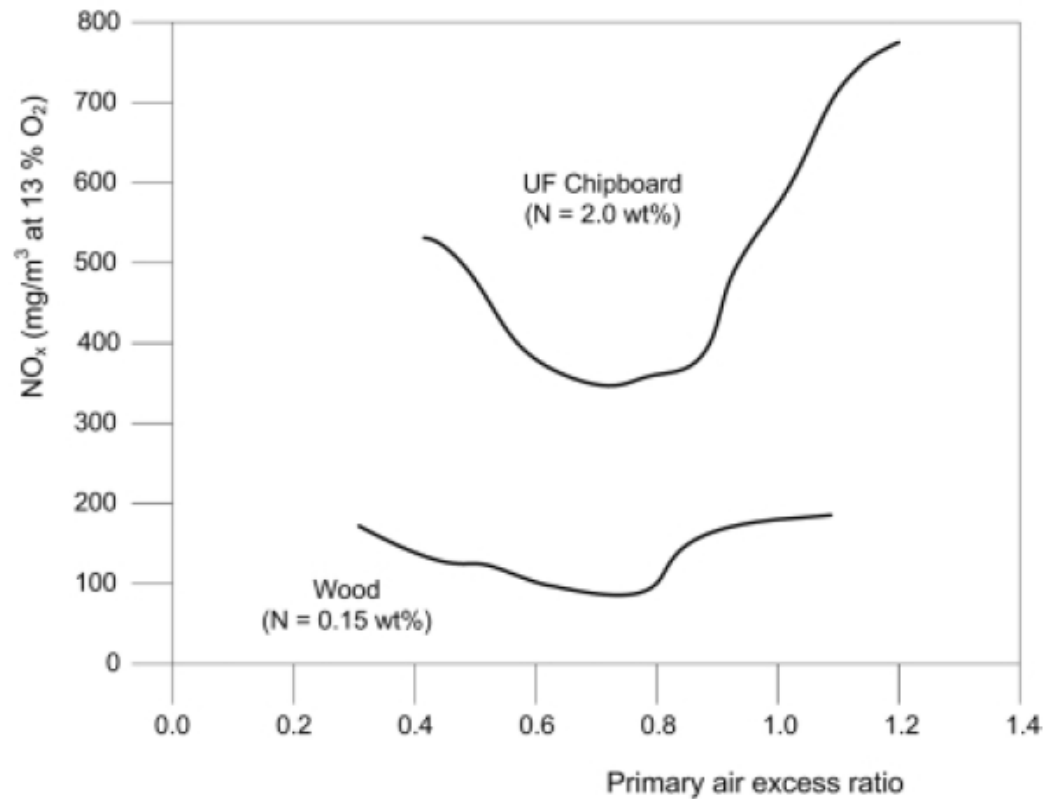

Explanations: Source: [4]



## Air staging strategies for medium sized fire-tube boilers – low-NO<sub>x</sub> pilot-scale combustion plant – evaluation of the technology I

### ■ Conclusions regarding the research performed

#### ■ The results gained from the project show clear tendencies concerning the effects of air staging on NO<sub>x</sub> reduction:

- With decreasing primary air ratio the NO<sub>x</sub> emissions decrease. For plant II a distinct NO<sub>x</sub> emission minimum could be identified in the  $\lambda_{\text{primary}}$  range between 0.7 and 0.9. This result is in line with literature. Since false air intake has not been considered, the real value of the optimum for  $\lambda_{\text{primary}}$  could be lower if less false air intake prevails.
- For plant I this minimum could not be identified, most probably due to the fact that no test runs with  $\lambda_{\text{primary}} < 0.8$  could be performed with the travelling grate technology (partly due to the grate technology, maybe also due to false air flows)
- The influence of false air was not investigated within this project, but within Future BioTEC it should be considered in any case.





## Air staging strategies for medium sized fire-tube boilers – low-NO<sub>x</sub> pilot-scale combustion plant – evaluation of the technology I

### ■ Conclusions regarding the research performed (continued)

- Also regarding the total air ratio an influence on NO<sub>x</sub> emissions could be identified:
  - With decreasing total air ratio also the NO<sub>x</sub> emissions decreased. However, this could also have been due to an overlapping with the decreasing primary air ratios
    - more systematic research is still needed
- No data concerning the influence of air ratios on total dust and PM<sub>1</sub> emissions are available from these tests



## Air staging strategies for medium sized fire-tube boilers – low-NO<sub>x</sub> pilot-scale combustion plant – evaluation of the technology II

### ■ Conclusions regarding the research performed (continued)

#### ■ Further relevant parameters influencing NO<sub>x</sub> emission reduction

- It has clearly been shown that the NO<sub>x</sub> emission reduction efficiency increases with increasing residence time in the primary combustion zone (detected for different fuels)
- No relevant influence of the temperature in the primary combustion chamber on NO<sub>x</sub> emissions could be detected.

#### ■ Consequence for the further investigations within FutureBioTec:

- All parameters influencing a reduction of NO<sub>x</sub> emissions have to be considered during the test runs planned.
- During the evaluation it has to be carefully worked out, which emission reduction effects can be allocated to changes in the air staging and which are attributed to other parameters such as residence time, furnace temperature and total air ratio.
- The release of NO<sub>x</sub> precursors from the fuel bed has to be considered and is especially relevant for CFD simulations.



## Air staging strategies for medium sized fire-tube boilers – low-NO<sub>x</sub> pilot-scale combustion plant – evaluation of the technology III

### ■ Conclusions regarding the research performed (continued)

#### ■ Consequence for the further investigations within FutureBioTec:

- More systematic investigations regarding the influence of different parameters on NO<sub>x</sub> emissions and a variation in a broader range are needed:
  - Influence of  $\lambda_{\text{total}}$  and  $\lambda_{\text{primary}}$
  - Influence of the temperature in the primary combustion zone
  - Influence of the load
  - Influence of flue gas recirculation on  $\lambda_{\text{primary}}$ , temperature in the primary combustion zone and mixing conditions
  - Measurement of air flows and determination of false air and its effects on  $\lambda_{\text{primary}}$  and the temperature in the primary combustion zone
- A further evaluation of literature data concerning kinetic effects (residence time, temperature...) should be done.
- The evaluation of the test runs should be supported by detailed CFD-based NO<sub>x</sub> simulations in order to be able to evaluate the path of N-compounds in more detail.



## Air staging strategies for medium-scale boilers – multi-fuel/low-dust combustion technology – description of technology I

### ■ Basic data

- **Name of technology:** Multi-fuel-/low-dust combustion technology
- **Manufacturer:** POLYTECHNIK Luft- und Feuerungstechnik GmbH

### ■ Basic information about the combustion concept

- **Nominal boiler capacity in kW<sub>th</sub>:** 9,200  
System is applied in the capacity range between about 1,000 and 16,000 kW)
- **Fuels used:** wood chips, sawdust, shavings, chipboard residues  
(moisture content typically below 30 wt% w.b.)
- **Boiler technology:** thermal oil boiler  
(system is also used with fire-tube hot water boilers and fire-tube steam boilers)
- **Fuel feeding system:** 3 parallel stoker screws



## Air staging strategies for medium-scale boilers – multi-fuel/low-dust combustion technology – description of technology II

- **Basic information about the combustion concept (continued)**
  - **Grate technology:**
    - inclined moving grate
  - **Geometry of the furnace:**
    - Co-current flow concept with primary and secondary combustion zone (secondary combustion zone divided into a horizontal duct above the primary zone and a subsequent vertical duct for improved burnout)
  - **Furnace materials and insulation:**
    - insulated furnace walls



## Air staging strategies for medium-scale boilers – multi-fuel/low-dust combustion technology – description of technology III

### ■ Basic information about the combustion concept (continued)

#### ■ General description of the control strategy:

##### – load control:

controlled variable: feed temperature

manipulated variable: fuel supply, primary air supply

##### – combustion control:

controlled variable: O<sub>2</sub> content in the flue gas

manipulated variable: secondary air supply

##### – furnace temperature:

controlled variable: temp. in the secondary combustion zone

manipulated variable: flue gas recirculation

#### ■ Partial load behaviour:

continuous operation at 20 – 100% of nominal load possible



## Air staging strategies for medium-scale boilers – multi-fuel/low-dust combustion technology – description of technology IV

- **Basic information concerning the air staging strategy applied**
  - **Combustion air distribution concept**
    - **Primary combustion air** supplied below the grate in 3 separated zones with independently controllable air fans
    - **Secondary combustion air** supplied above the grate and from the front side (fuel input side).
  - **Geometric concept of the furnace with respect to air staging**
    - Defined geometric separation of primary and secondary combustion zone.
    - The secondary air is injected above the grate into the upper part of the first combustion chamber



## Air staging strategies for medium-scale boilers – multi-fuel/low-dust combustion technology – description of technology V

### ■ Basic information concerning the air staging strategy applied (continued)

#### ■ Flue gas recirculation

- Flue gas is recirculated below the grate (deducted after the flue gas fan) as well as above the grate (deducted before the flue gas fan) from the side walls and the front side
- These two flue gas recirculation options are realised with separate ducts and separate flue gas recirculation fans
- recirculation rate: 0.23 – 0.40 depending on fuel moisture content, excess oxygen ratio and temperature settings  
(the plant is designed for fuels with a moisture content up to 30 wt% w.b.)





## Air staging strategies for medium-scale boilers – multi-fuel/low-dust combustion technology – description of technology VI

- **Basic information concerning the air staging strategy applied**
  - **Flexibility concerning air staging and air distribution setup**
    - Due to the application of separately controlled air fans for primary and secondary air supply generally a high flexibility regarding the adjustment of the air staging exists
  - **Combustion air and air distribution controls applied**
    - All air and flue gas recirculation fans are frequency controlled
    - However, no measurements of primary and secondary air as well as flue gas recirculation flows exist. The air staging is therefore adjusted by experience based on the frequency settings of the different fans and is not actually controlled.
    - The total air ratio is controlled by adjusting the secondary air supply to a certain O<sub>2</sub> content in the flue gas at boiler outlet



# Air staging strategies for medium-scale boilers – multi-fuel/low-dust combustion technology – pictures/schemes of technology

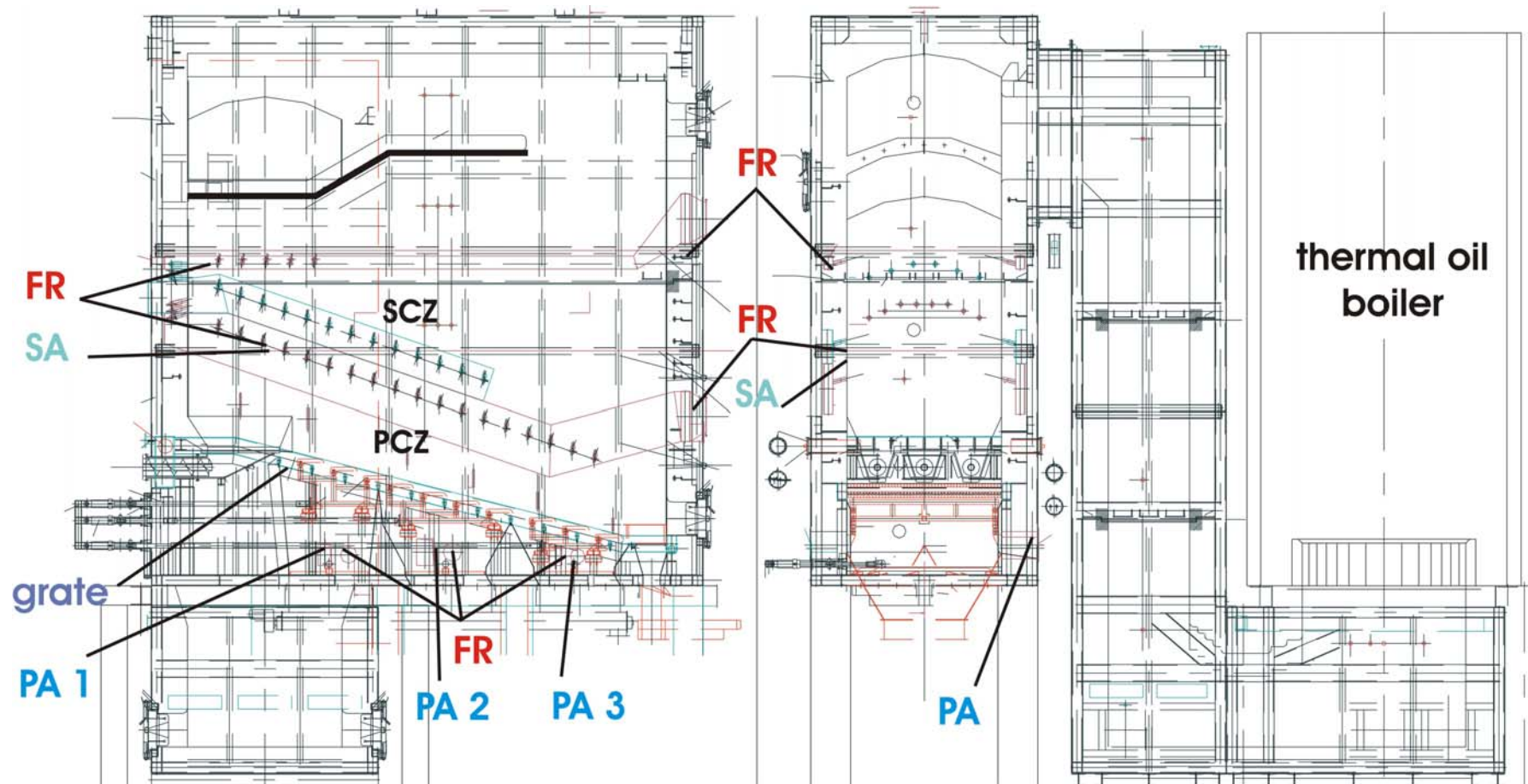



## Air staging strategies for medium-scale boilers – research performed on multi-fuel/low-dust combustion technology

### ■ Objectives of the research work performed

Within a research project 3 different biomass fuels were tested at the plant

- mixture of wood chips and wood dust
- chipboard residues
- wood dust

### ■ Methodology applied

The plant was operated at constant load conditions (almost full load) at the usual settings concerning total air ratio, flue gas recirculation and air staging.

No variations of these parameters have been performed.

### ■ Results

On the following slides the results of the single measurement campaigns are presented.



## Air staging strategies for medium-scale boilers – research performed on multi-fuel/low-dust combustion technology

### ■ Measurement equipment applied

- O<sub>2</sub>: paramagnetic sensor
- CO: ND-IR
- NO<sub>x</sub>: CLD
- Total dust: according to VDI 2006
- PM<sub>1</sub>: 9-stage Berner-type low-pressure impactor

- **Due to the almost complete burnout (CO<100 mg/Nm<sup>3</sup> related to dry flue gas and 13 vol% O<sub>2</sub>) prevailing in this plant no OGC measurements have been performed**



## Air staging strategies for medium-scale boilers – research performed on multi-fuel/low-dust combustion technology

- **Measurement of air flows and recirculated flue gas**
  - **The primary and secondary air flows as well as the flue gas recirculation flows were not measured by the plant process control system.**
  - **Therefore the air flows were estimated based on**
    - the fan characteristics  
(pressure vs. volume flow lines for different rotation speeds)
    - the recorded frequency of the air fans
    - the positions of the primary and secondary air valves and a calculation of the pressure losses of the air supply lines
  - **Comparisons of these estimated air flows and the air flows calculated based on mass and energy balances over the plant were in good agreement.**
  - **The estimation of the flue gas recirculation flows lead to implausible results. Therefore, the calculated mass flows based on mass and energy balances were used for the evaluations.**



## Air staging strategies for medium-scale boilers – research performed on multi-fuel/low-dust combustion technology

### ■ Biomass fuel composition

fuel		wood chips and dust	chipboard residues	wood dust
water content	wt% (w.b.)	15.3	6.3	6.4
ash content	wt% (d.b.)	0.4	1.49	0.31
C	wt% (d.b.)	51.6	49.2	49.1
H	wt% (d.b.)	6.4	6.24	5.9
N	wt% (d.b.)	0.15	3.65	0.1
S	mg/kg (d.b.)	53	477	56
Cl	mg/kg (d.b.)	25	190	19
Ca	mg/kg (d.b.)	1040	2080	898
K	mg/kg (d.b.)	439	639	318
Si	mg/kg (d.b.)	395	787	225
Mg	mg/kg (d.b.)	142	266	117
P	mg/kg (d.b.)	24	149	19
Na	mg/kg (d.b.)	7	239	13
Fe	mg/kg (d.b.)	33	150	7
Al	mg/kg (d.b.)	40	846	11
Mn	mg/kg (d.b.)	83	82	84
Zn	mg/kg (d.b.)	10	35	9
Cu	mg/kg (d.b.)	0.75	2.05	0.7
GCV	kJ/kg (d.b.)	20,500	19,600	20,400
NCV	kJ/kg (w.b.)	13,003	16,922	12,454
K+Na+Zn	mg/kg (d.b.)	456	913	340
2S/Cl	[-]	4.7	5.6	6.5
(K+Na)/(2S+Cl)	[-]	2.9	0.8	2.2
Si/K	[-]	1.3	1.7	1.0

Explanations:

d.b. ... dry base

w.b. ... wet base

GCV ... gross calorific value

NCV ... net calorific value



## Air staging strategies for medium-scale boilers – research performed on multi-fuel/low-dust combustion technology

- **Plant operation (load and temperatures)**
  - **Comparable and stable plant operation at >95% of the nominal load**
  - **Combustion temperatures in a comparable range**

		wood chips and dust		chipboard residues		wood dust	
		mean value	st.dev.	mean value	st.dev.	mean value	st.dev.
thermal output	kW	8,997	165	9,010	58	8,757	105
combustion temperature 1	°C	920	5.5	876	4.6	860	3.9
combustion temperature 2	°C	910	13.7	938	2.5	865	4.7
combustion temperature 3	°C	810	11.5	886	8.2	808	5.1
combustion temperature 4	°C	812	12.4	735	3.0	777	4.5
combustion temperature 5	°C	890	5.0	847	3.7	883	1.6
combustion temperature 6	°C	851	10.2	833	3.5	874	3.7

Explanations: st.dev. ... standard deviation;  
 combustion temperatures 1 to 6: different temperature measurement points following the flue gas pathway through the primary and secondary combustion zone  
 combustion temperature 1: above the fuel bed  
 combustion temperature 2: above the secondary air nozzles  
 combustion temperature 3: middle of the secondary combustion zone  
 combustion temperature 4: middle of the horizontal duct of the secondary combustion zone  
 combustion temperature 5 and 6: in the vertical duct of the secondary combustion zone



## Air staging strategies for medium-scale boilers – research performed on multi-fuel/low-dust combustion technology

### ■ Air ratios, flue gas recirculation and emissions

- During the test runs the plant was operated with a good air staging.
- The flue gas recirculation ratio was varied from 0.23 for the fuel mixture (highest moisture content) to 0.40 for chipboard residues.
- Residence time of the flue gas in the primary zone: 0.50 – 0.71 s  
Residence time of the flue gas in the secondary zone 3.03 – 3.40 s  
(based on CFD simulations)

		wood chips and dust	chipboard residues	wood dust
residence time primary zone	s	0.60	0.50	0.71
residence time in secondary zone	s	3.40	3.03	3.30

	wood chips and dust	chipboard residues	wood dust
Lambda_total	1.98	1.80	1.84
Lambda_primary	0.75	0.50	0.62
recirculation ratio	0.23	0.40	0.34

	O <sub>2</sub> [vol% dry flue gas]		NO <sub>x</sub> [mg/MJ]		CO [mg/MJ]	
	mean value	st.dev.	mean value	st.dev.	mean value	st.dev.
wood chips and dust	10.5	1.4	57.7	12.2	23.5	47.3
chipboard residues	9.3	0.8	242.5	26.3	5.8	1.8
wood dust	9.6	0.4	58.3	9.8	6.9	10.4

Emissions related to dry flue gas





## Air staging strategies for medium-scale boilers – research performed on multi-fuel/low-dust combustion technology

- Conversion of fuel-N into N bound in  $\text{NO}_x$  emissions
  - Comparison with results from the MAWERA plant ([1])
  - With primary air ratios between 0.50 and 0.75 and residence times of the flue gas in the primary combustion zone of 0.5 – 0.7s at temperatures of  $>800^\circ\text{C}$  a good air staging was reached resulting in comparably low fuel-N to  $\text{NO}_x$  conversion ratios

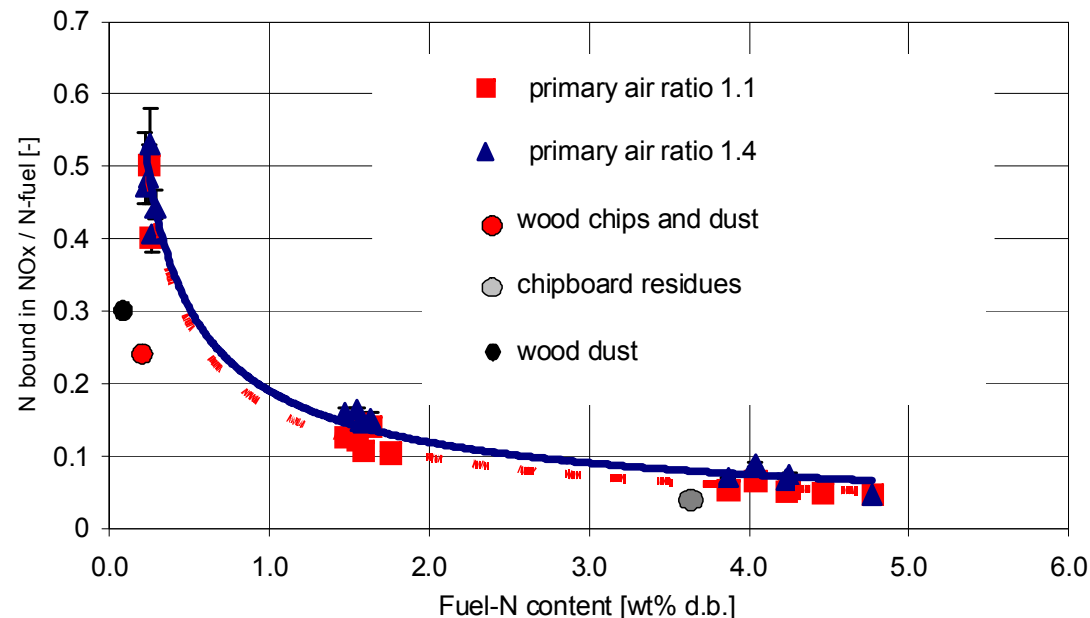



## Air staging strategies for medium-scale boilers – research performed on multi-fuel/low-dust combustion technology

### ■ Total dust (TSP) emissions

- Highest total dust emissions downstream the economiser for chipboard residues (225.2 mg/MJ)
- Good correlation between ash content and TSP emissions
- Comparably low TSP emissions for chipboard combustion when taking the ash content of 1.49 wt% (d.b.) into consideration  
 → partly an effect of the low primary air ratio

		wood chips and dust	chipboard residues	wood dust
total dust	mg/MJ	101.2	225.2	78.6
coarse fly ash	mg/MJ	77.4	191.4	53.1

Emissions in dry flue gas related to 13 vol% O<sub>2</sub>

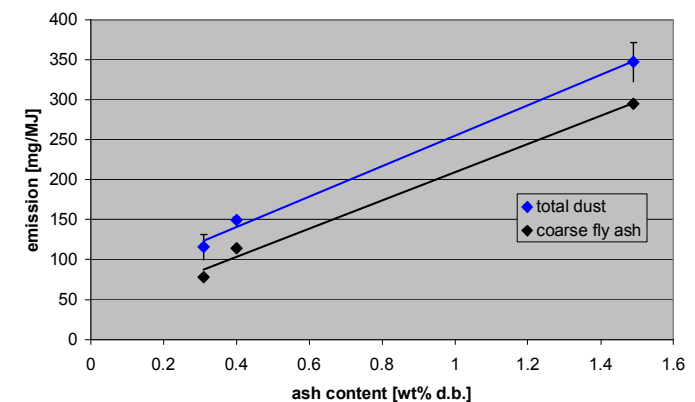
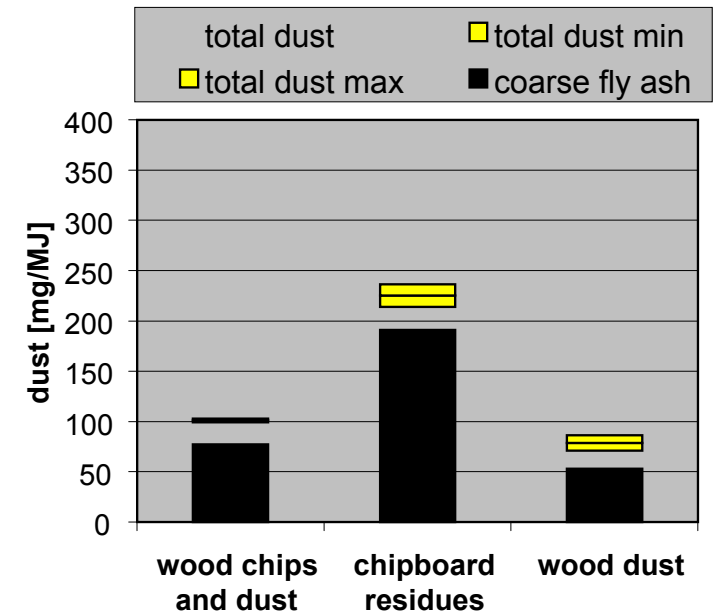



## Air staging strategies for medium-scale boilers – research performed on multi-fuel/low-dust combustion technology

### ■ Aerosol (PM<sub>1</sub>) - emissions

- Highest aerosol emissions for chipboard residues (33.8 mg/MJ)
- Compared with other fuels good correlation between the concentration of aerosol forming elements in the fuel (K, Na, Zn, Pb) and the PM<sub>1</sub> emissions (see next slide)

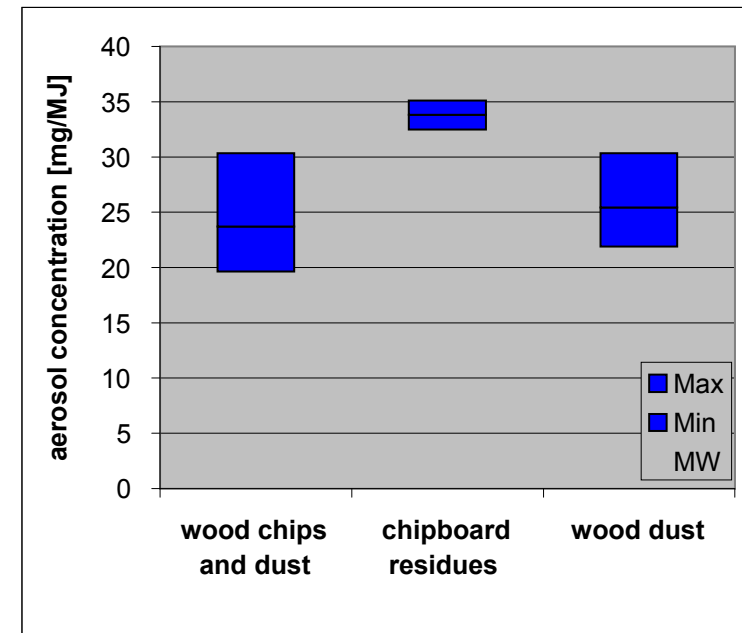

fuel		wood chips and dust	chipboard residues	wood dust
O <sub>2</sub> -concentration	vol% dry flue gas	10.7	9.5	9.7
flue gas temperature an measurement point	°C	185.8	185.5	184.3
thermal output (thermal oil)	kW	8,853	8,759	8,682
<b>aerosol concentration (13 vol% dry flue gas)</b>	<b>mg/MJ</b>	<b>23.7</b>	<b>33.8</b>	<b>25.4</b>



## Air staging strategies for medium-scale boilers – research performed on multi-fuel/low-dust combustion technology

### ■ Aerosol (PM<sub>1</sub>) emissions vs. fuel composition – comparison with database values

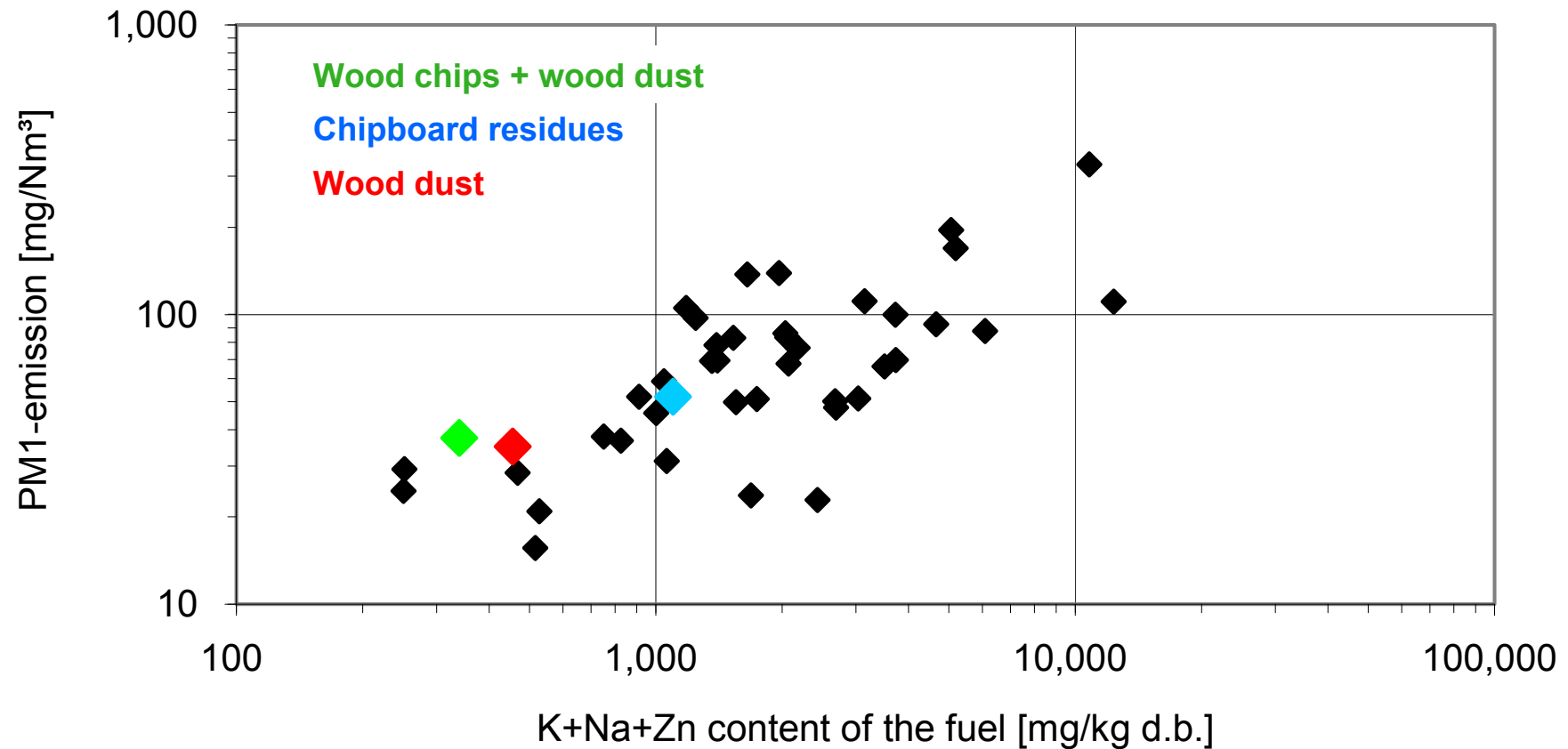



## Air staging strategies for medium-scale boilers – multi-fuel/low-dust combustion technology – evaluation of the technology I

- **Primary and total air ratios achieved in real operation**
  - **primary air ratios at full load: 0.50 – 0.75**
  - **total air ratios at full load: 1.80 – 1.98**
  - **residence time primary combustion zone: 0.50 – 0.71**
  
- **False air measurements/calculations**
  - **The estimation of the primary and secondary air flows indicated a good correlation with the mass and energy balances leading to the conclusions that the false air rate in the plant is below 10%.**
  
- **How is air staging implemented within the concept?**
  - **Good implementation and realisation of air staging in the concept leads to comparably low NO<sub>x</sub> emissions.**



## Air staging strategies for medium-scale boilers – multi-fuel/low-dust combustion technology – evaluation of the technology II

- **Does the control concept support the air staging concept by an appropriate control of the air flows/flue gas recirculation during different combustion / load phases?**
  - The air flows and flue gas recirculation are controlled by the frequency of the fans as well as valves but not measured.
  - The air flows are varied during different load phases but there is no control regarding the distribution of the air between primary and secondary air.
  - The air staging settings are optimised for full load operation which does not necessarily mean, that also during partial load optimised settings prevail.
  
- **Does the concept also appropriately work at partial load?**
  - During the test runs no measurements at partial load were performed.



## Air staging strategies for medium-scale boilers – multi-fuel/low-dust combustion technology – evaluation of the technology III

### ■ Conclusions regarding the research performed

- The concept represents a sound and appropriate solution for implementing air staging in medium-scale combustion plants in order to minimise NO<sub>x</sub> emissions and keep TSP emissions low.
- For all fuels investigated low NO<sub>x</sub>, CO, TSP and PM<sub>1</sub> emissions were detected.
- Highest NO<sub>x</sub>, TSP and PM<sub>1</sub> emissions for chipboard residues due to highest N- and ash content in the fuel.

### ■ Potentials for optimisation

- Enlargement of the primary combustion zone (zone before secondary air injection) to achieve an even higher NO<sub>x</sub> reduction for N-rich fuels should be investigated (by CFD simulations).
- Control of the air staging (primary air ratio) also during partial load would be meaningful.
- Further reduction of the primary air ratio in order to reduce the K-release from the fuel bed to the gas phase (reduced primary air ratio → reduce PM<sub>1</sub> emission formation [6]).



## Air staging strategies – CFD simulations

- **Literature: [12], published in 2008**
- **Objectives**
  - **Development and verification of simulation models regarding NO<sub>x</sub> formation in biomass combustion plants**
- **Methods**
  - **Simulations for varying primary air ratios in a biomass combustion systems were performed:**
    - **440 kW<sub>th</sub> grate furnace (see slide 86)**
    - **CFD-models applied: gas phase combustion model, empirical packed-bed model, k-ε model for turbulence, Eddy Dissipation Concept for turbulence-chemistry interaction and skeletal Kilpinen97 reaction mechanism**
  - **Comparison with results from measurements performed with fibreboard as fuel**





# Air staging strategies – CFD simulations – results I

- nominal boiler load 440 kW<sub>th</sub>
- separated primary and secondary combustion zone with enlarged primary combustion zone
- flue gas recirculation below and above the fuel bed
- fuel: fibreboard
- 2 different operating cases (with respect to  $\lambda_{\text{prim}}$ )

fibreboard		operating case	
		FB 1	FB 2
C-content	[wt% d.b.]	46.8	46.8
H-content	[wt% d.b.]	6.1	6.1
O-content	[wt% d.b.]	42.5	42.5
N-content	[wt% d.b.]	3.1	3.1
ash content	[wt% d.b.]	1.7	1.7
water content	[wt% w.b.]	10.6	10.6

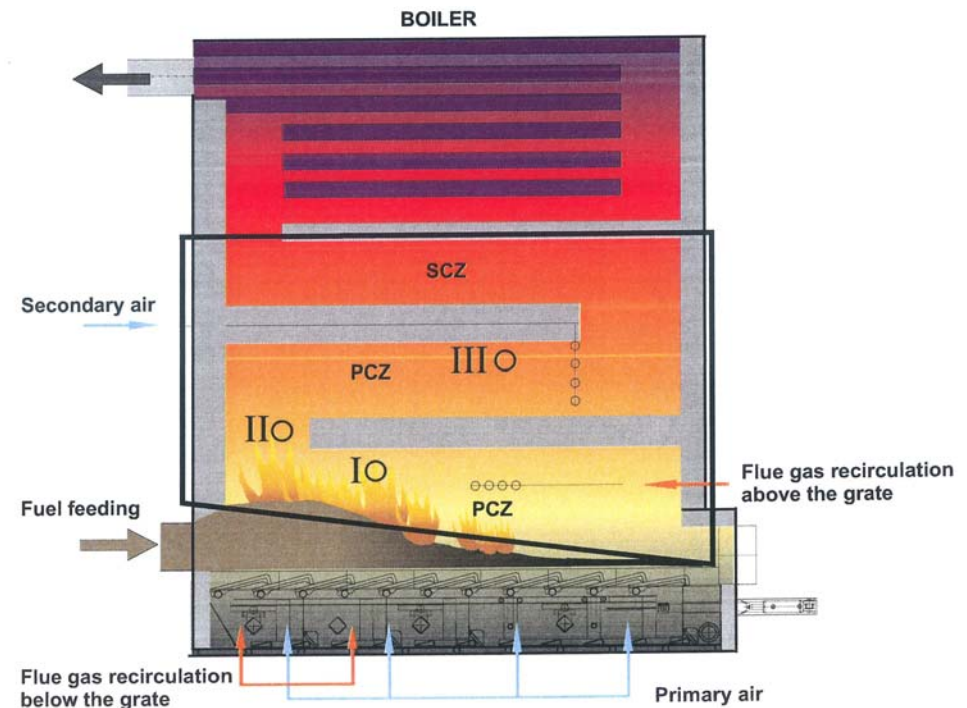



# Air staging strategies – CFD simulations – results II

		operating case	
		FB 1	FB 2
fibreboard			
boiler output	[kW]	418	429
$\lambda_{\text{prim\_eff}}$	[-]	1.63	0.97
$\lambda_{\text{total}}$	[-]	1.61	1.41
recirculation ratio	[-]	0.46	0.49
NOx emissions			
simulated	[ppmv]	293	256
measured	[ppmv]	264	264

$\lambda_{\text{prim\_eff}}$  including flue gas recirculation

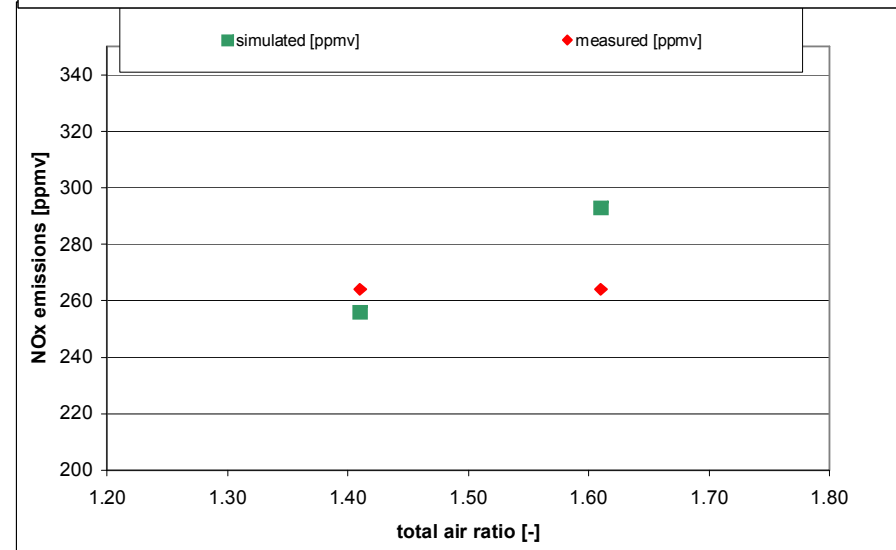
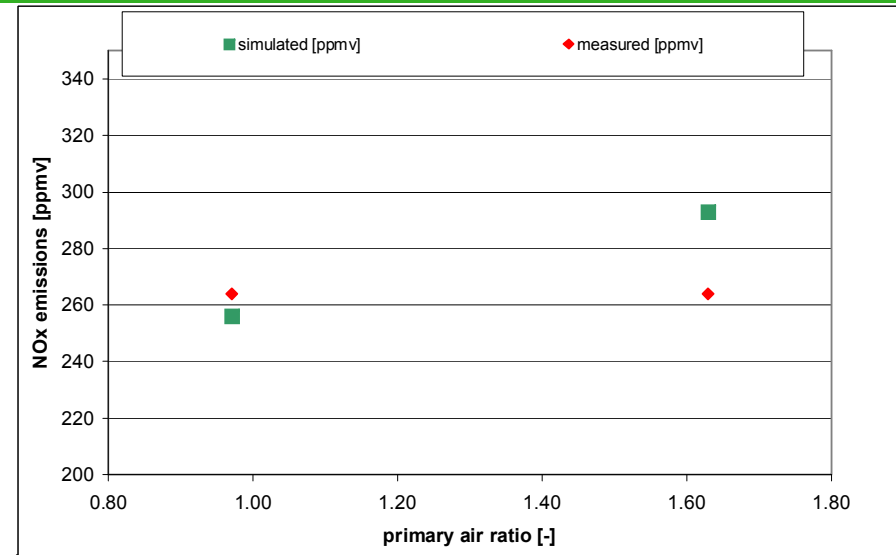



## Air staging strategies – general conclusions I

### ■ Residential heating boilers:

- Primary combustion chambers in residential heating boilers are often too small (short residence time) for an efficient  $\text{NO}_x$  reduction → enlargement
- False air (especially from the fuel feeding system) often significantly influences the primary air ratio and enhances strain formation (incomplete mixing)
- Better air staging concept at partial load needed
- Limited data/research available



## Air staging strategies – general conclusions II

### ■ Medium sized fire-tube boilers:

- For minimum  $\text{NO}_x$  emissions an optimum  $\lambda_{\text{primary}}$  in the range between 0.7 and 0.9 was identified
- A minimal residence time in the primary combustion zone of 0.5 s has to be ensured in order to minimise  $\text{NO}_x$  emissions
- A minimal temperature in the primary combustion zone of  $800^\circ\text{C}$  is essential for reduced  $\text{NO}_x$  emissions
- An evaluation of the false air intake is important
  - influence on the effective primary air ratio achieved
  - influence regarding mixing of flue gases and combustion air
- An air staging control for all load conditions would be relevant
- Only limited data from research projects are available



# Air staging strategies – general conclusions III

- Present state-of-the-art regarding the conversion of fuel-N into NO<sub>x</sub> emissions in medium-scale combustion plants equipped with air staging

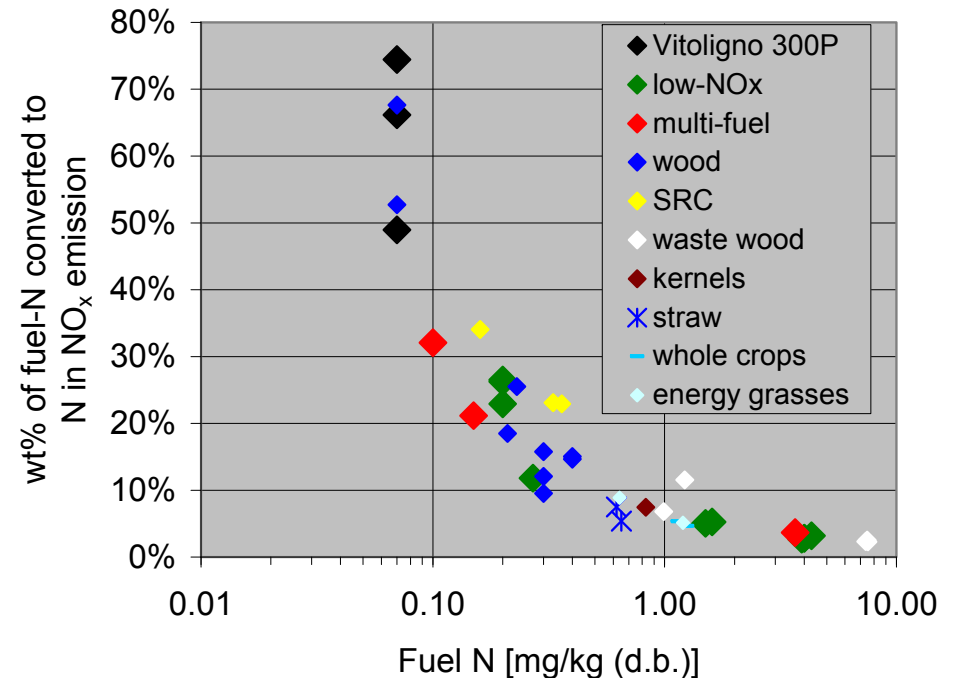
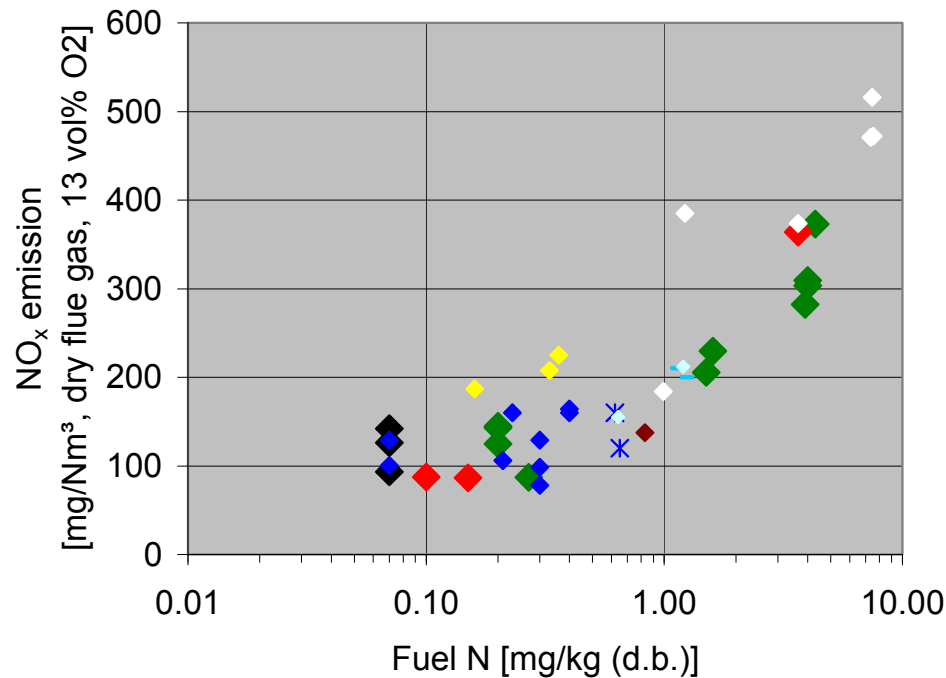



## Air staging strategies – general conclusions IV

- In present medium-scale furnace and boiler concepts air staging is usually applied as a standard strategy for minimising emissions
- However, in most cases air staging is applied but not optimised which is due to lack of information regarding the correct application of air staging
- Therefore, the full potentials of air staging as an efficient emission reduction measure are still not used. Weak points and possible optimisations:
  - No systematic approaches for adjusting and optimising the primary air ratios with respect to the actual state of the combustion process (load, fuel quality etc.) have been implemented so far.
  - No attempts for the utilisation of air staging as a measure to reduce the release of ash forming elements from the fuel bed have so far been performed.



## Air staging strategies – general conclusions V

- No appropriate **control system** which also controls the air ratios during load changes has been implemented so far.
- Air staging during **partial load operation** has not been comprehensively investigated yet.
- **Reduction of false air** (e.g. from the fuel feeding system) to achieve good air staging and a well controlled primary air ratio.
- An optimum of the primary and total air ratios for minimised **CO emissions** has to be identified.
- The influencing parameters on **NO<sub>x</sub> emissions** (mainly  $\lambda_{\text{primary}}$ ,  $\lambda_{\text{total}}$ , temperature and residence time of the flue gas in the primary combustion zone) shall be studied comprehensively.
- The influence of the primary air ratio on **PM<sub>1</sub> emissions** (by evaluation of element release) as well as on **coarse fly ash emissions** shall be evaluated.
- Then an overall strategy regarding a low-NO<sub>x</sub> and low-dust combustion technology shall be defined.



## Air staging strategies – general conclusions VI

### - Results of CFD simulations performed

- **Good agreement of simulated and measured NO<sub>x</sub> emissions.**
- **A clear reduction of NO<sub>x</sub> emissions with decreasing primary and total air ratios was identified.**
- **The reduction of the primary air ratio is limited by an increased tar-release and a poor burn-out.**
- **Flue gas recirculation in the primary combustion zone leads to an effective mixing and a good temperature control in the zone.**
- **The residence time in the primary combustion zone influences the NO<sub>x</sub> emissions. A residence time of about 0.7s is sufficient.**
- **A backflow of secondary air into the primary combustion zone influences the residence time (decreasing) and mixing effects in the primary combustion zone and therefore should be avoided.**





## References I

- [1] WEISSINGER A., 2002: Experimentelle Untersuchungen und theoretische Simulationen zur  $\text{NO}_x$ -Reduktion durch Primärmaßnahmen bei Rostfeuerungen, PhD thesis, Institute for Chemical Engineering, Fundamentals and Plant Engineering, Graz University of Technology, Graz, Austria
- [2] WEISSINGER , A. and OBERNBERGER, I., 1999:  $\text{NO}_x$  reduction by primary measures on a travelling-grate furnace for biomass fuels and waste wood, Proceedings of the 4th Biomass Conference of the Americas, Pergamon, pp1417–1424
- [3] WEISSINGER, A. and OBERNBERGER, I., 1999:  $\text{NO}_x$  reduction by primary measures on a travelling — grate furnace for biomass fuels and waste wood',. In: Proceedings of the 4th Biomass Conference of the Americas, September 1999, Oakland (California), USA, ISBN 0 08 043019 8, Elsevier Science Ltd. (ed.), Oxford, UK, pp 1417—1425
- [4] NUSSBAUMER, T., 1997: Primary and secondary measures for the reduction of nitric oxide emissions from biomass combustion', in Developments in Thermochemical Biomass Conversion, Blackie Academic & Professional, pp1447–1461
- [5] BRUNNER T., 2006: Aerosols and coarse fly ashes in fixed-bed biomass combustion. PhD-thesis, book series "Thermal Biomass Utilization", Volume 6, Graz University of Technology. ISBN 3-9501980-2-4
- [6] NUSSBAUMER T., 2003: Combustion and Co-combustion of Biomass: Fundamentals, Technologies, and Primary Measures for Emission Reduction, Energy & Fuels, Vol. 17, No 6, 2003, 1510–1521
- [7] ZAHIROVIC S., 2008: CFD analysis of gas phase combustion and  $\text{NO}_x$  formation in biomass packed-bed furnaces, PhD thesis, Institute for Process Engineering, Faculty of Chemistry, Chemical and Process Engineering, Graz University of Technology, Graz, Austria



# Summary and Evaluation of Existing Data on Air Staging Strategies in Switzerland

**Report based on literature data from Nussbaumer et. al.  
Compiled by BIOENERGY 2020+ GmbH, Austria  
Project ERA-NET "Future BioTec"**



## Air staging strategies – literature research – Nussbaumer et. al. regarding NO<sub>x</sub> emission reduction I

- **Literature: [1], [2], [3], published in 1997 and 1998**
- **Objectives**
  - **Investigations regarding the influence of air staging and flue gas recirculation on NO<sub>x</sub> emission formation in an underfeed stoker fired biomass combustion system**
- **Methods**
  - **Test runs at a 250 kW biomass combustion plant (prototype)**
    - underfeed stoker
    - well separated primary and secondary combustion zone
    - flue gas recirculation (mixed with the primary combustion air)
  - **Fuels applied: wood chips, chipboard residues**
  - **Parameters investigated regarding influence on NO<sub>x</sub> emissions:**
    - total and primary air ratio
    - flue gas recirculation
    - application of an optimised control concept



## Air staging strategies – literature research – Nussbaumer et. al. regarding NO<sub>x</sub> emission reduction II

### Scheme of the combustion plant

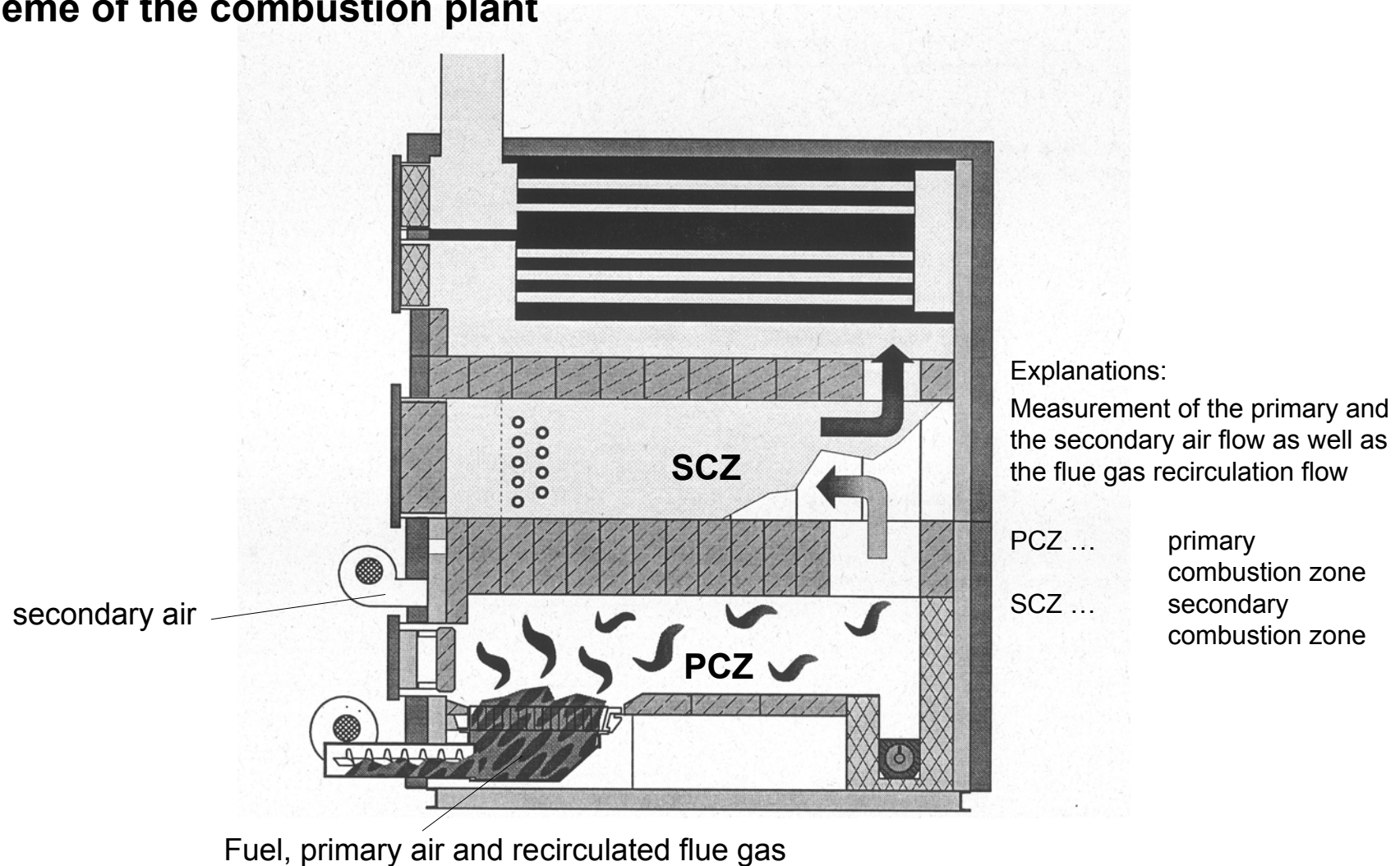



## Air staging strategies – literature research – Nussbaumer et. al. regarding $\text{NO}_x$ emission reduction III

- Results:  $\text{NO}_x$  emissions as a function of the primary air ratio and flue gas recirculation

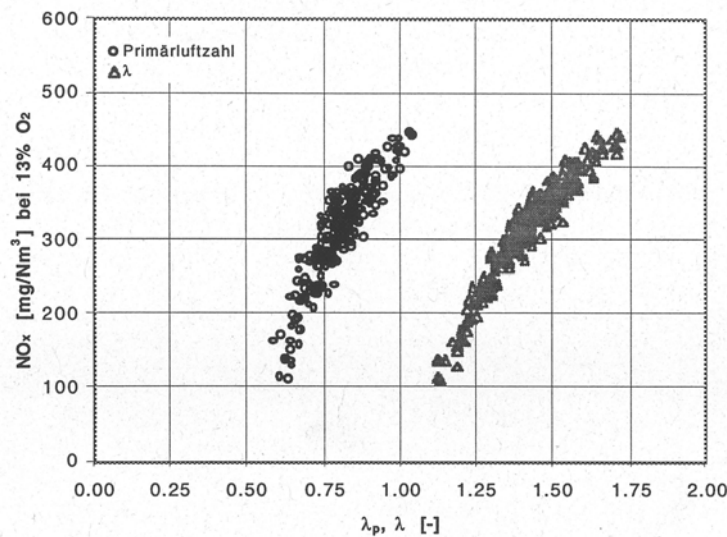

without flue gas recirculation

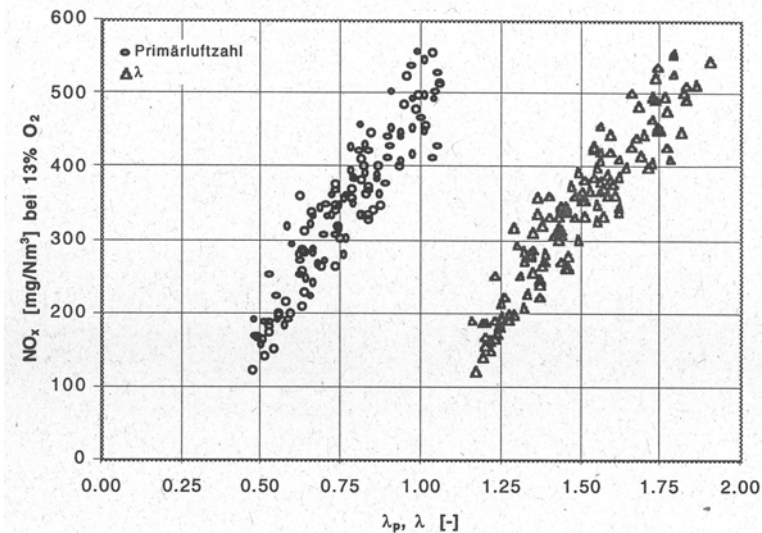

with flue gas recirculation

Explanations: fuel applied: chipboard residues (moisture content: <10 wt% w.b.)  
 flue gas recirculation ratio: 35%; boiler load: ~135 kW without and ~125 kW with flue gas recirculation



## Air staging strategies – literature research – Nussbaumer et. al. regarding NO<sub>x</sub> emission reduction III

### ■ Results: NO<sub>x</sub> emissions as a function of the primary air ratio

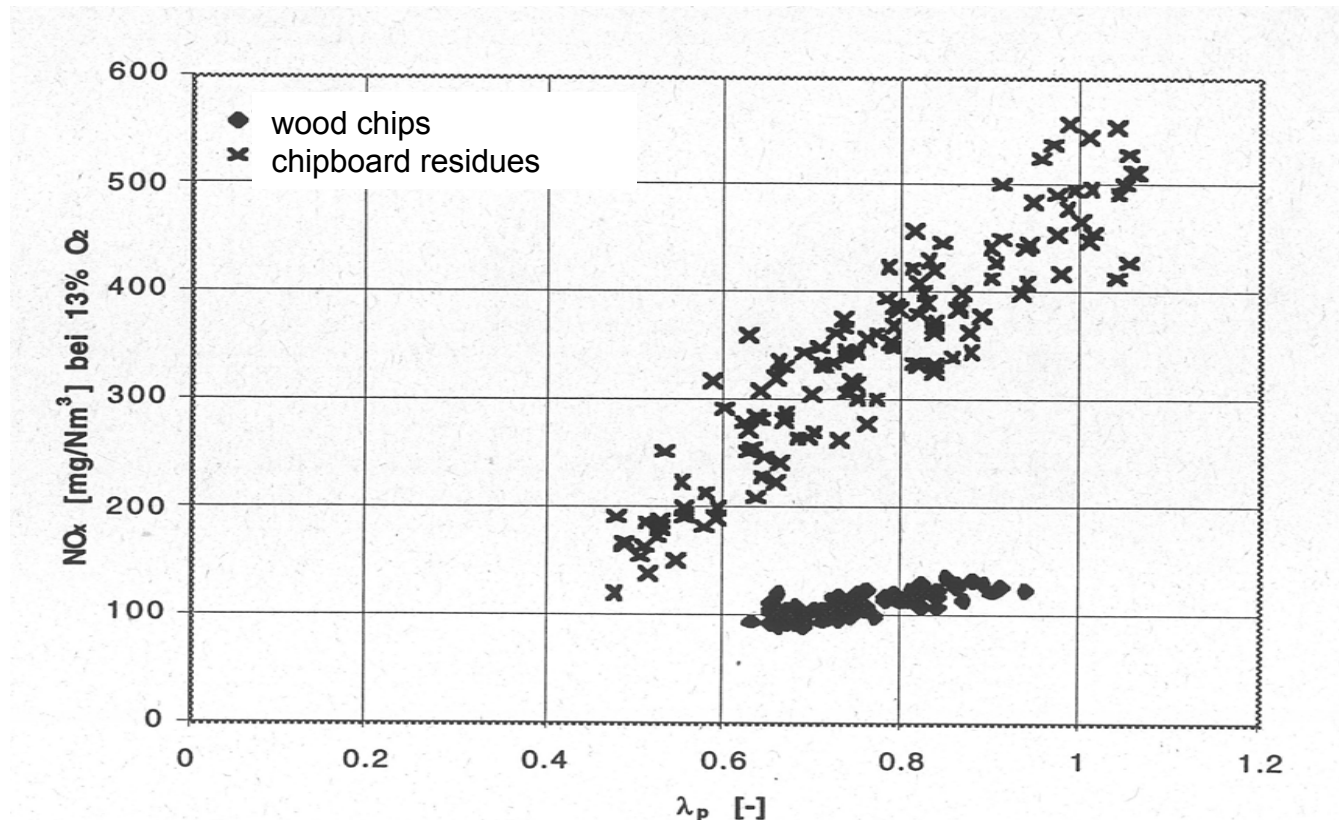

Explanations: fuels applied: wood chips (moisture content: 20 wt% w.b.); chipboard residues (moisture content: <10 wt% w.b.)  
 flue gas recirculation ratio: 35% (for both fuels); boiler load: ~125 kW (both fuels)  
 temperature in the primary combustion chamber ~1,150°C (wood chips) and ~1,075°C (chipboard residues)



## Air staging strategies – literature research – Nussbaumer et. al. regarding NO<sub>x</sub> emission reduction IV

### ■ Results

- A separate primary combustion zone (reducing conditions) must be implemented in the furnace concept.
- Significantly decreasing NO<sub>x</sub> emissions with decreasing  $\lambda_{\text{prim}}$
- No significant influence of flue gas recirculation on NO<sub>x</sub> emissions
- Optimised operation conditions for low-NO<sub>x</sub> operation at low CO emissions:
  - $\lambda_{\text{prim}}$ : 0.6 to 0.8
  - $\lambda_{\text{total}}$ : 1.2 to 1.5
  - residence time in the primary combustion zone: >0.3 – 0.5 s
  - temperature in the primary combustion zone: 1,100 – 1,200°C
- The measurement of the primary and the secondary air flow as well as of the recirculated flue gas flow is recommended for an optimised control of the primary air ratio.



## Air staging strategies – literature research – Nussbaumer et. al. regarding NO<sub>x</sub> emission reduction V

- Applying a  $\lambda$ -control for low-NO<sub>x</sub> operation the NO<sub>x</sub> emissions could be reduced by 30% (compared with the state-of-the-art in the late 1990ies).
- Using a further developed control concept (CO/ $\lambda$ -control and temperature control by flue gas recirculation) the NO<sub>x</sub> emissions for wood chip combustion could be reduced by even 41%.
- For biomass fuels with low N-content (<0.5 wt% d.b.) air staging showed a potential for NO<sub>x</sub> reduction in the range of 40 – 60% (compared with plants without air staging).
- For biomass fuels with high N-content (>1 wt% d.b.) air staging showed a potential for NO<sub>x</sub> reduction in the range of 50 – 75% (compared with plants without air staging).
- **Comments:**
  - false air intake has not been considered in the evaluations  
→ the real  $\lambda_{\text{prim}}$  values could be even higher
  - most test runs have been performed at partial load





## Air staging strategies – literature research – Nussbaumer et. al. regarding TSP emission reduction I

- **Literature:** [4], [5], [6], [7]; published in 2003 and 2004
- **Objectives**
  - Investigation of parameters influencing TSP emissions from biomass combustion
- **Methods**
  - **Test runs performed at a pilot-scale combustion plant**
    - underfeed stoker
    - well separated primary and secondary combustion zone
    - flue gas recirculation (mixing with primary air)
  - **Parameters investigated:**
    - different biomass fuels  
(wood chips, chipboard residues, pellets)
    - primary air ratio



## Air staging strategies – literature research – Nussbaumer et. al. regarding TSP emission reduction II

### ■ Results: TSP emissions as a function of the primary air ratio

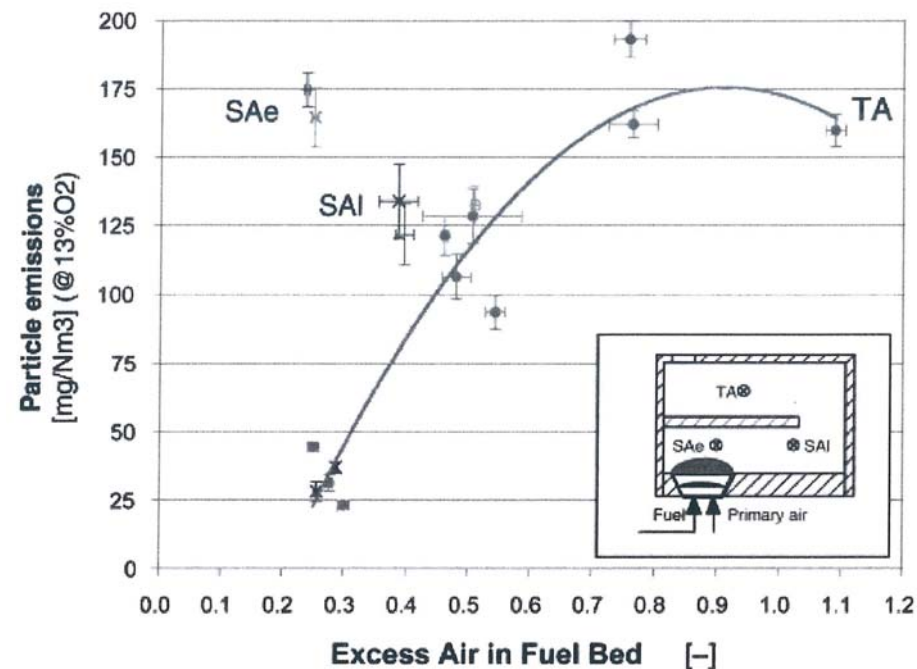

Explanations: different air settings according to the location in the small graph; TA ... tertiary air (curve); SAe ... secondary air early; SAl ... secondary air late  
 fuels applied: wood chips, chipboard residues and pellets  
 (no further information available)



## Air staging strategies – literature research – Nussbaumer et. al. regarding TSP emission reduction III

### ■ Results

- TSP emissions can be reduced by the factor 5 by applying low primary air ratios.
- TSP emissions below 33 mg/MJ were achieved for most of the fuels used when applying primary air ratios around 0.3.
- When firing biomass fuels with higher moisture content an even flow through the bed has to be guaranteed to minimise particle emissions (particle entrainment due to bed channelling).
- The lowest TSP emissions could be achieved for pellets. Beech wood chips and chipboard residues showed higher TSP emissions.
- It is postulated that by reducing the primary air flow also the release of K as an aerosol forming element from the fuel to the gas phase and consequently aerosol emissions can be reduced. This has however not been confirmed by measurements.



## Air staging strategies – literature research – Nussbaumer et. al. regarding TSP emission reduction IV

### ■ Comments

- **False air intake has not been considered within this project.**
- **Only TSP emissions and no aerosol emissions have been investigated.**
- **Regarding the TSP emissions it is not clear whether the differences are due to the primary air ratio variations or due to other influencing variables such as fuel particle size and ash content.**



## References I

- [1] NUSSBAUMER, T., 1997: Primary and secondary measures for the reduction of nitric oxide emissions from biomass combustion', in Developments in Thermochemical Biomass Conversion, Blackie Academic & Professional, pp1447–1461
- [2] NUSSBAUMER T., 1998: Furnace design and combustion control to reduce emissions and avoid ash slagging, Final report of the Triennium, 1995 - 1997, International Energy Agency, Biomass Combustion Activity, Zürich
- [3] GOOD J. et.al., 1998: Konstruktive Massnahmen und Prozessregelung zur Optimierung der NO<sub>x</sub>-Minderung durch Luftstufung in einer Unterschubfeuerung, Schlussbericht EU-Projekt JOR3CT96: Low-NO<sub>x</sub> Wood Chip Combustion, Bundesamt für Energie und Bundesamt für Bildung und Wissenschaft, Zürich
- [4] NUSSBAUMER T., 2003: Combustion and Co-combustion of Biomass: Fundamentals, Technologies, and Primary Measures for Emission Reduction, Energy & Fuels, Vol. 17, No 6, 2003, 1510–1521
- [5] OSER M. et.al., 2003: Grundlagen der Aerosolbildung in Holzfeuerungen: Beeinflussung der Partikelemissionen durch Primärmassnahmen und Konzept für eine partikelarme automatische Holzfeuerung (Low-Particle-Feuerung), Schlussbericht Projekt 26688, Bundesamt für Energie, Bundesamt für Umwelt, Wald und Landschaft, Zürich und Bern 2003, ISBN 3-908705-02-9
- [6] OSER M. et.al., 2003: Grundlagen der Aerosolbildung in Holzfeuerungen: Beeinflussung der Partikelemissionen durch Primärmassnahmen und Konzept für eine partikelarme automatische Holzfeuerung (Low-Particle-Feuerung), Jahresbericht Projekt 26688, Bundesamt für Energie, Bundesamt für Umwelt, Wald und Landschaft, Zürich und Bern 2003
- [7] OSER M. et.al., 2004: Low-Particle-Pelletfeuerungen im Leistungsbereich von 100 bis 500 kW, Schlussbericht Projekt 100373, Bundesamt für Energie, Zürich 2004, ISBN 3-908705-09-6



# Summary and Evaluation of Existing Data on Air Staging Strategies in Finland

**Country report**

**Prepared by University of Eastern Finland**

**Project ERA-NET "Future BioTec"**



## Air Staging Strategies in Finland - overview over the technologies investigated I

- **Automated residential heating boilers (pellets, logwood and wood chips, up to 100 kW<sub>th</sub>)**
  - Residential pellet boiler technology
  - Pellet burner technology based on gasification and combustion
- **Medium sized fire-tube boilers (up to 20 MW)**
  - No reliable data from this category available
- **Water tube steam boilers (up to 20 MW)**
  - No reliable data from this category available



## Air staging strategies for residential heating boilers – residential pellet boiler – description of technology I

- **small scale pellet boiler manufactured by Biotech GmbH model PZ-RL**
- **25 kW maximum output with top feed and lambda control**
- **separate primary and secondary air input**
  - controlled fans for each input
  - primary air fed through the grate, secondary air approximately 15 cm above the grate
  - 12 sec air inlets
- **tests with reduced primary and secondary air**
  - 75 % and 50 %
  - (lower output powers: 25 kW, 12.5 kW and 7 kW)





## Air staging strategies for residential heating boilers – residential pellet boiler – description of technology II

### ■ Basic data

- Name of technology: Pellet boiler model PZ-RL
- Manufacturer: Biotech

### ■ Basic information about the combustion concept

- Nominal boiler capacity range in kW<sub>th</sub>: 25 kW
- Fuels used: wood pellets and sawdust
- Boiler technology: grate boiler
- Fuel feeding system: top fed system



## Air staging strategies for residential heating boilers – residential pellet boiler – description of technology III

- **Basic information about the combustion concept (continued)**
  - **Burner and grate technology:**
    - fixed grate
  - **Geometry of the furnace:**
    - cylindrically formed, opens up after secondary air input
  - **Furnace materials and insulation:**
    - steel
  - **General description of the control strategy:**
    - lambda controlled
  - **Partial load behaviour:**
    - continuous operation between 25 – 100% (6-25 kW) of nominal load
    - < 6 kW on/off mode



## Air staging strategies for residential heating boilers – residential pellet boiler – description of technology IV

- **Basic information concerning the air staging strategy applied**
  - **Combustion air distribution concept**
    - Primary air below grate
    - Circumferential injection of secondary air above the grate
  - **Geometric concept of the furnace with respect to air staging**
    - no efficient air staging concept regarding  $\text{NO}_x$  reduction exists
  - **Flue gas recirculation**
    - no flue gas recirculation applied
  - **specifying tests will be done in near future since new flow controlling instrument is available**



# Air staging strategies for residential heating boilers – residential pellet boiler – pictures/schemes of technology I

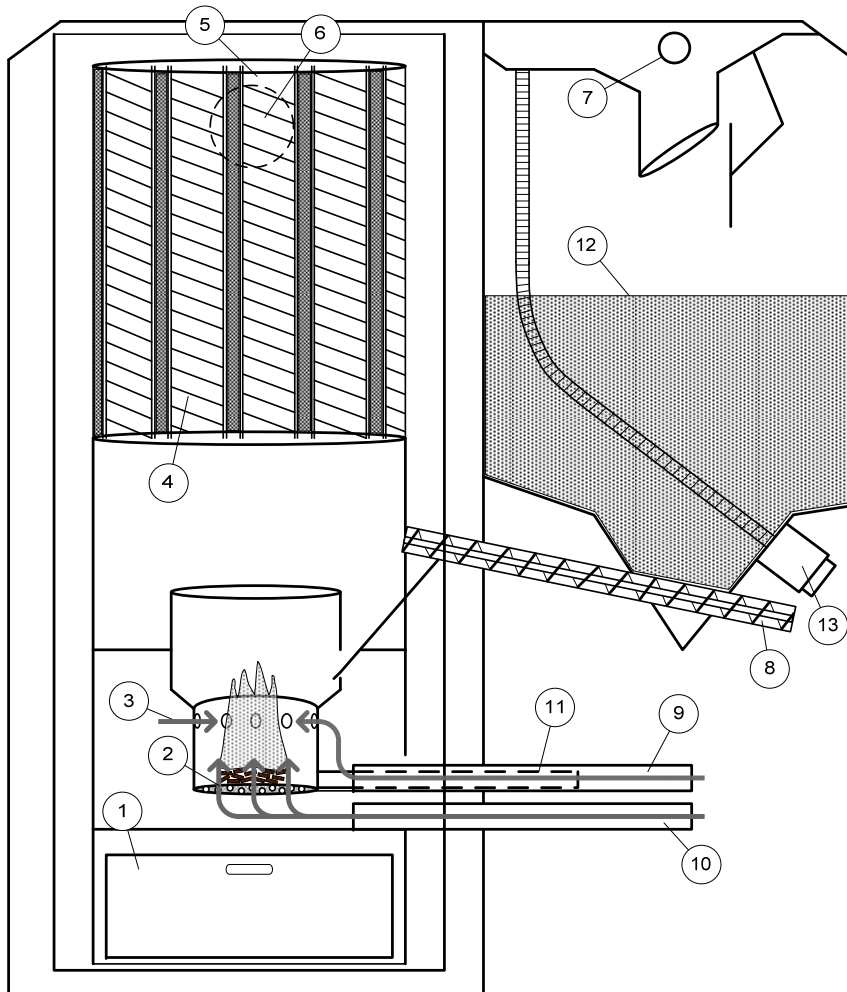



# Air staging strategies for residential heating boilers – residential pellet boiler – pictures/schemes of technology II

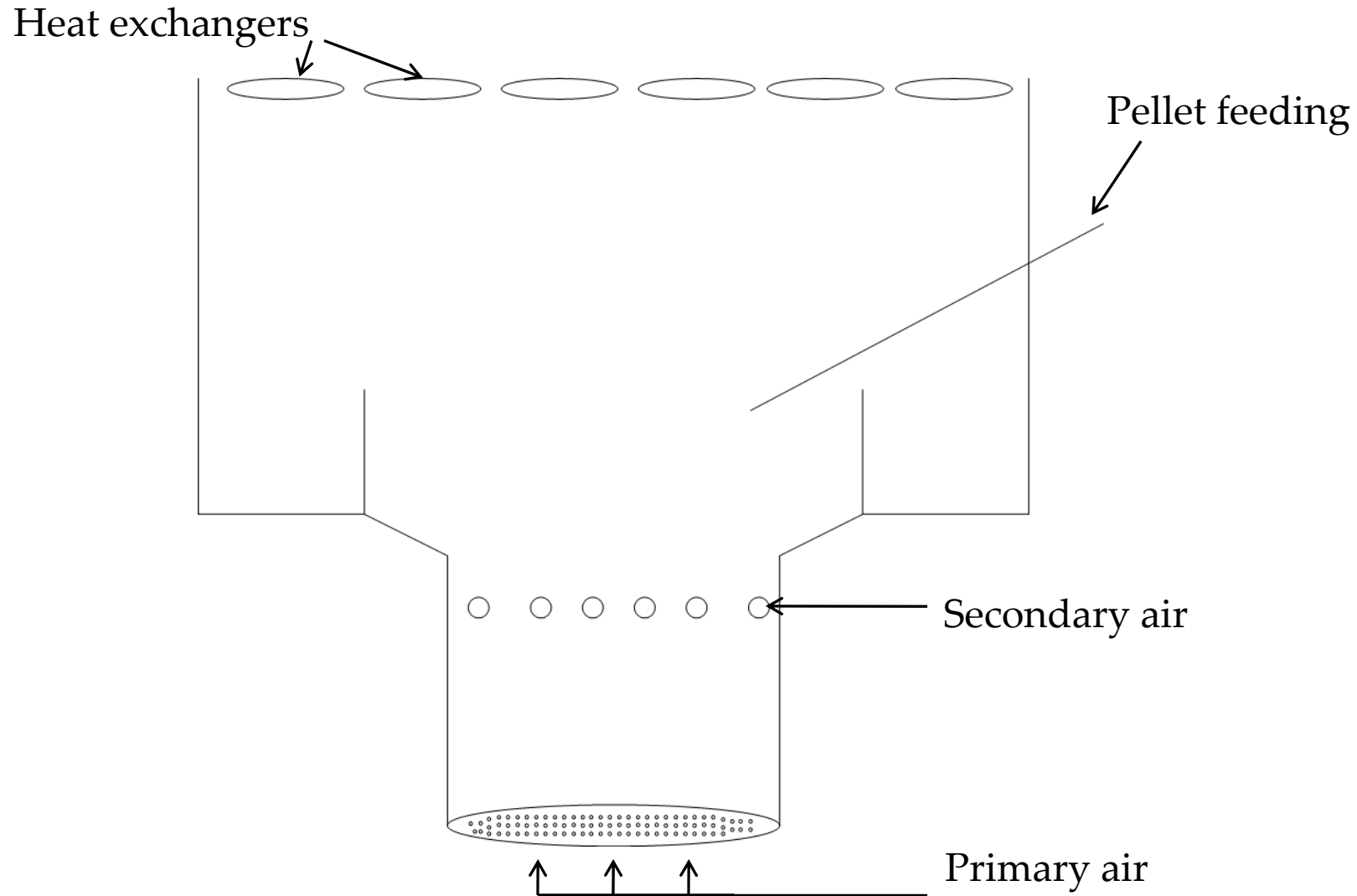



## Air staging strategies for residential heating boilers – residential pellet boiler – emissions (in mg/MJ)

- **Data provided by the manufacturer or type testing data**
  - **Institution which performed the measurements:**  
UEF, Lamberg et al. (2009) [1]
  - **CO:**
    - at full load: 64 mg/MJ
    - at 50% partial load: 132 mg/MJ
  - **NO<sub>x</sub>:**
    - at full load: 53 mg/MJ
    - at 50% partial load: 50 mg/MJ
  - **PM<sub>1</sub>:**
    - at full load: 12 mg/MJ
    - at 50% partial load: 15 mg/MJ



## Air staging strategies for residential heating boilers – research performed on residential pellet boiler - objectives

### ■ Objectives of the research work performed

- Effect of primary and secondary air settings on fine particle and gas emissions in small-scale pellet appliances

### ■ Methodology applied

- Measurement procedure for experiments with different air settings:
  - 3 hours operation with nominal load before each setting
  - 1 hour test run with the selected setting before measurements
  - 3 - 4 hour measurements with the selected setting  
(3 x 1 hour PM1 filter samples collected)
  - The online gas and particle measurements and the deviation of PM1 filters showed that the process was relatively stable during the measurements.



# Research performed on residential pellet boiler – scheme of the test stand

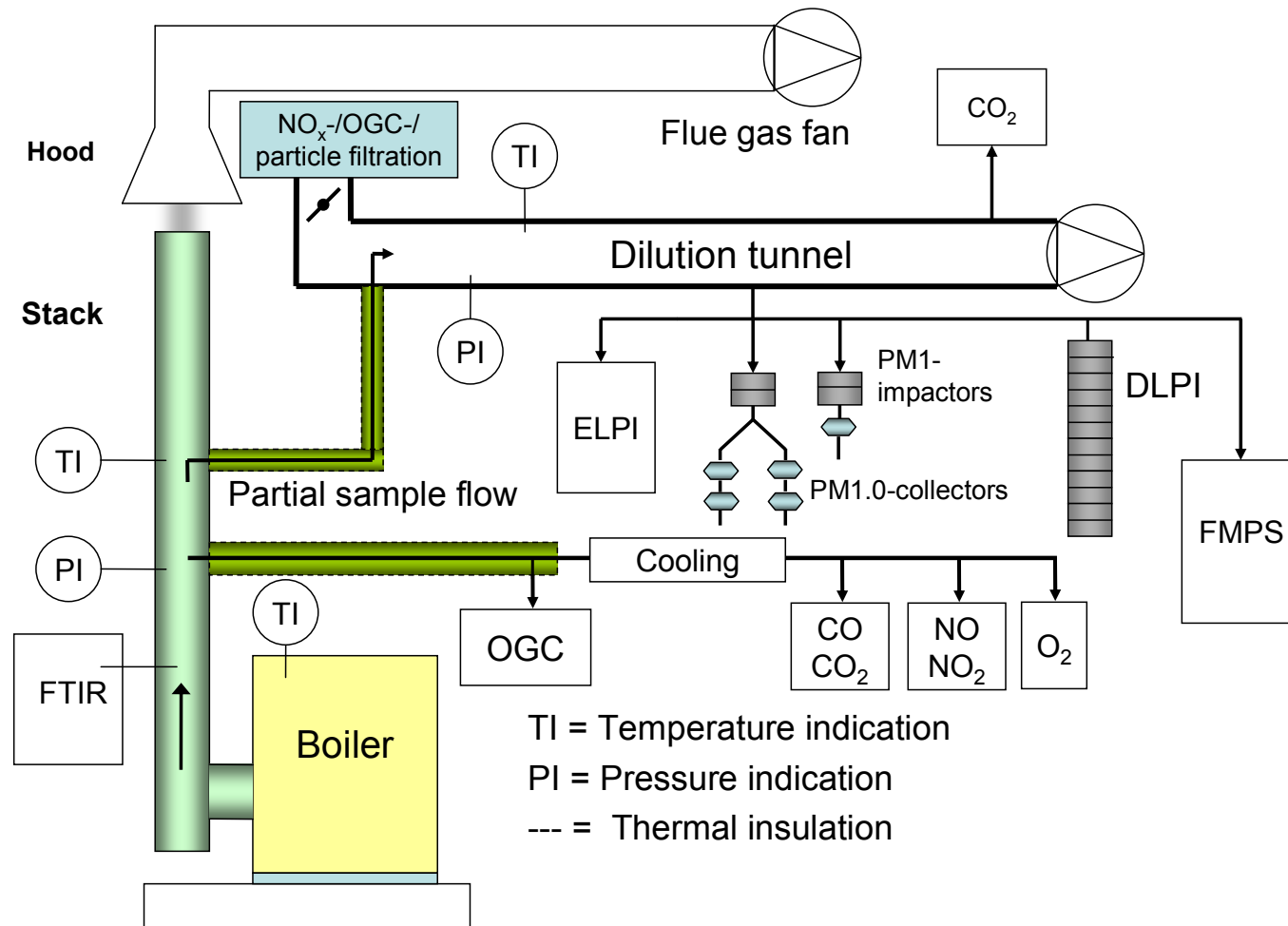





## Research performed on residential pellet boiler – emissions and operating conditions

		Nominal output 25 kW	Half output 12.5 kW	Low output 7 kW	Secondary air 75 %	Secondary air 50 %	Primary air 75 %	Primary air 50 %	Total air 70 %
PM1 (mg/MJ)	mean	12.20	15.27	16.32	16.10	29.04	5.88	3.02	18.37
	st. deviation ±	0.96	1.10	0.93	1.21	1.81	0.42	0.66	3.78
PM1 composition (mg/MJ)									
	Organic	0.51	2.46	0.83	2.44	5.51	0.95	0.16	5.88
	Elemental carbon	0.75	7.84	8.27	4.97	14.08	0.55	0.00	8.58
	Ash	10.94	4.97	7.22	8.69	6.87	4.38	2.86	4.47
Particle number emission ELPI [#MJ]mean		1.56E+13	1.38E+13	1.20E+13	2.88E+13	3.82E+13	2.22E+13	1.23E+13	1.86E+13
	st. deviation ±	3.01E+12	7.96E+12	4.47E+12	1.44E+13	2.23E+13	2.53E+12	2.11E+12	1.29E+13
	particle geom. mean ELPI (nm)	68.50	79.58	82.60	70.66	77.89	58.69	53.65	73.96
CO (mg/MJ)	mean	63.59	132.38	177.63	213.71	335.36	13.62	1.55	245.51
	st. deviation ±	56.32	112.36	101.64	189.03	292.15	10.56	7.06	241.33
<b>NOx (as NO2 equivalent) (mg/MJ)</b>	mean	80.95	76.17	79.32	74.85	72.76	76.19	83.35	
Flue gas O2 (%)	mean	9.83	13.03	14.70	9.47	10.12	10.13	10.39	9.40
	st. deviation ±	0.75	0.97	0.80	0.73	0.88	2.2E-03	2.1E-03	1.50
	lambda ?	1.93	2.69	3.41	1.84	1.95	1.95	1.99	1.88
	Primary ?	0.56	1.18	1.59	0.65	0.88	0.45	0.33	0.55
	Secondary ?	1.37	1.51	1.82	1.19	1.07	1.50	1.66	1.33
Boiler outlet temperature	ka.	154.16	84.60	75.17	139.93	117.07	127.19	110.55	106.33
	st. deviation ±	1.39	1.51	0.63	2.09	0.68	1.02	1.08	3.36



## Research performed on residential pellet boiler – emissions

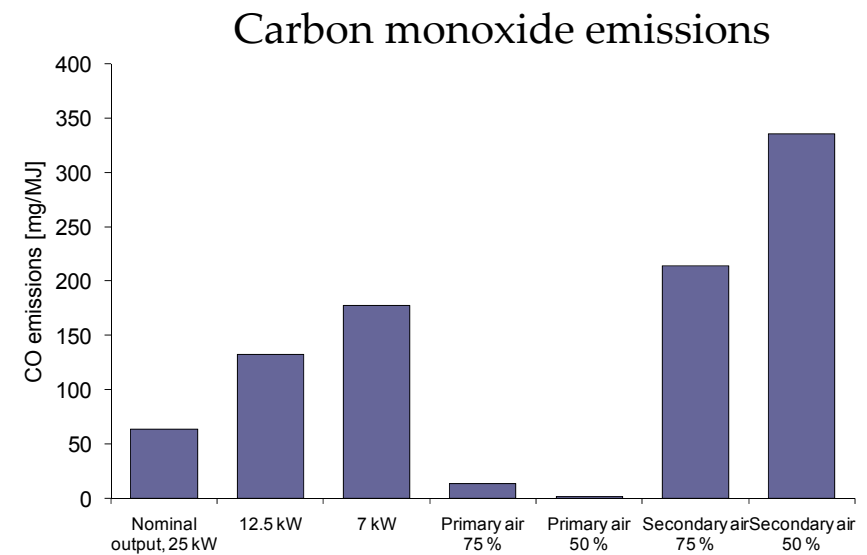
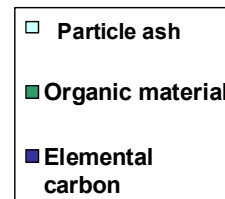
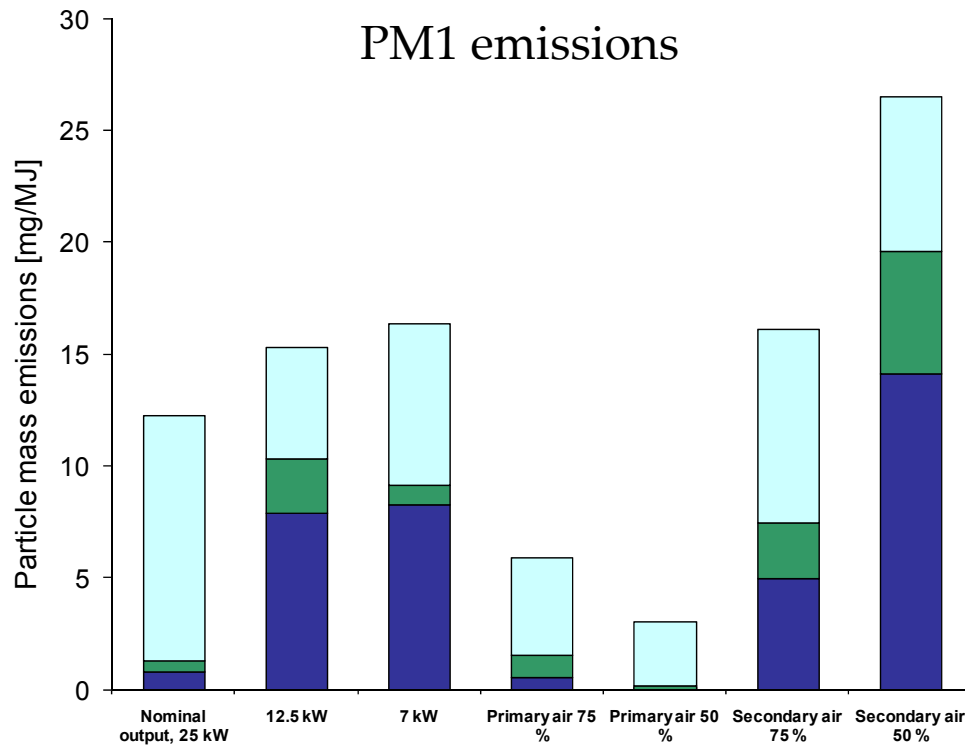

Source: [1]



## Research performed on residential pellet boiler – results I

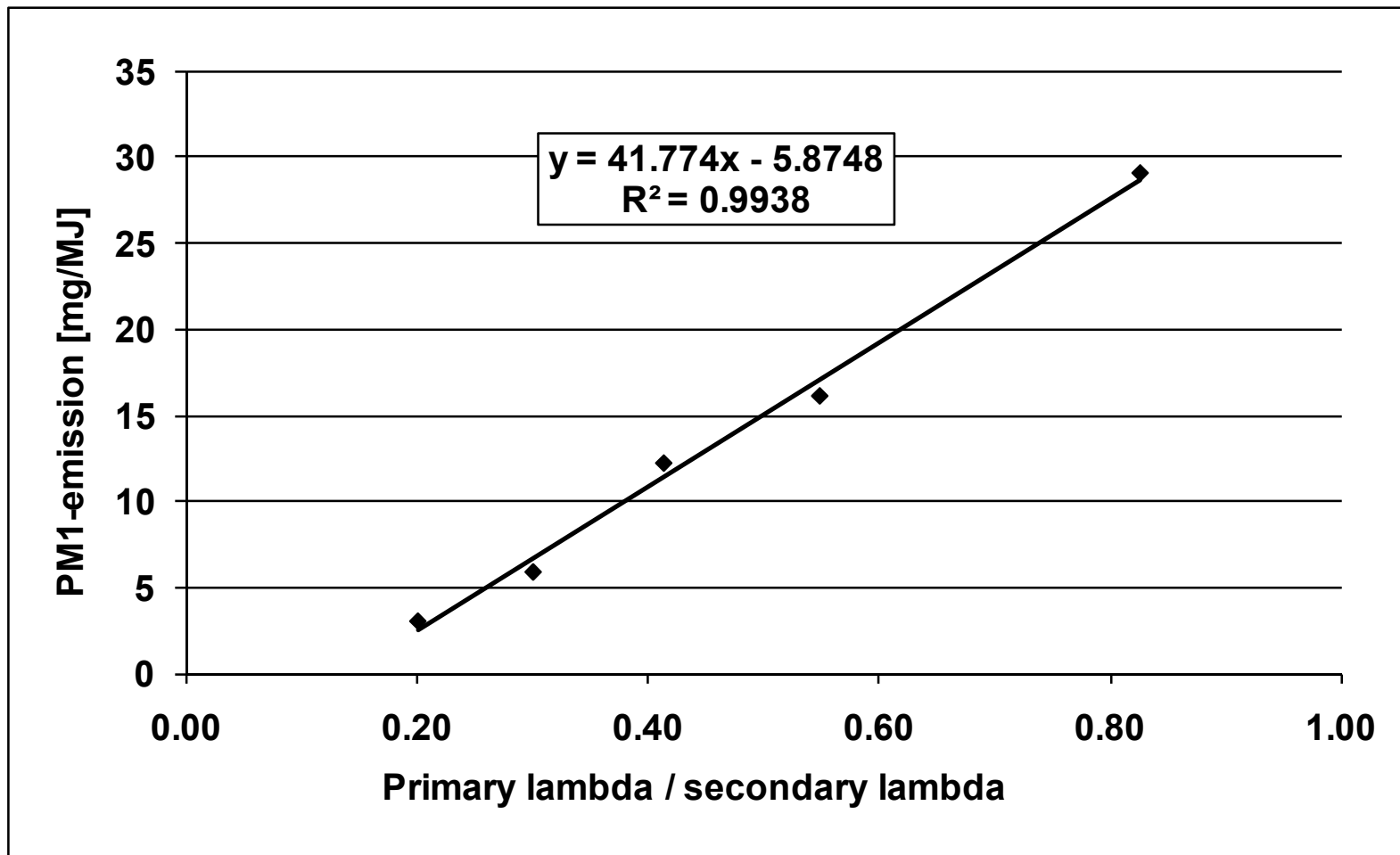

Source: [1]



## Research performed on residential pellet boiler – emissions and operating conditions

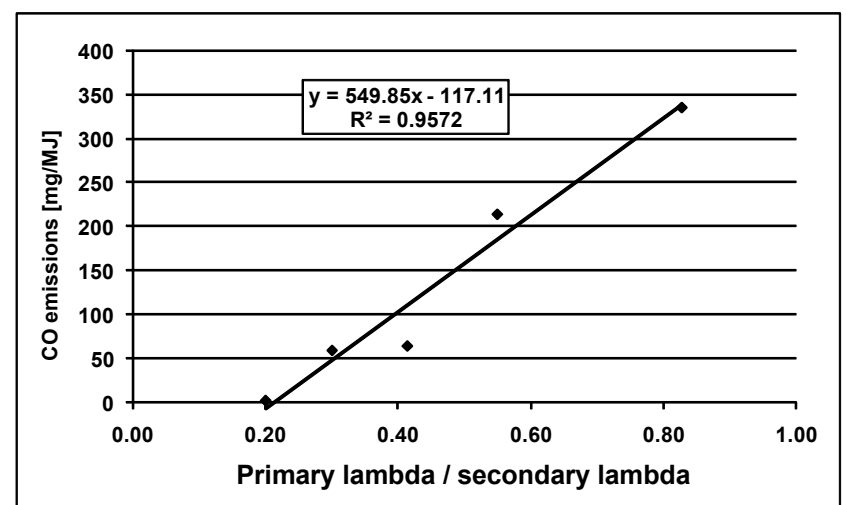
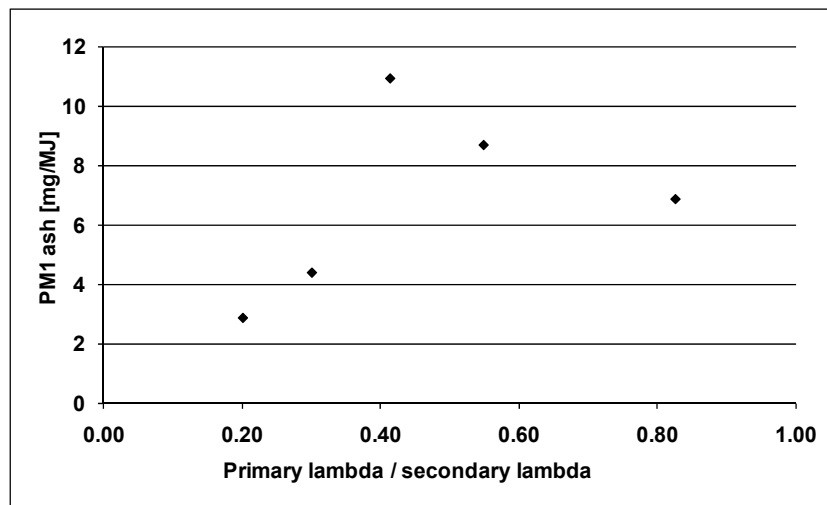
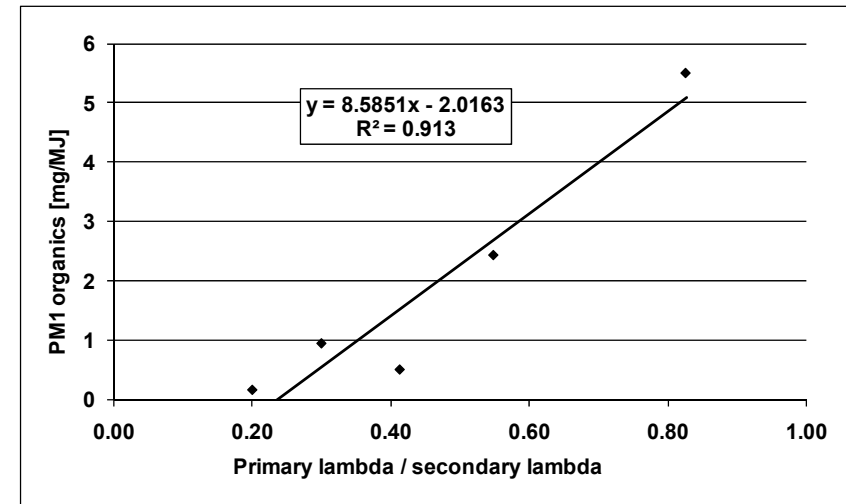
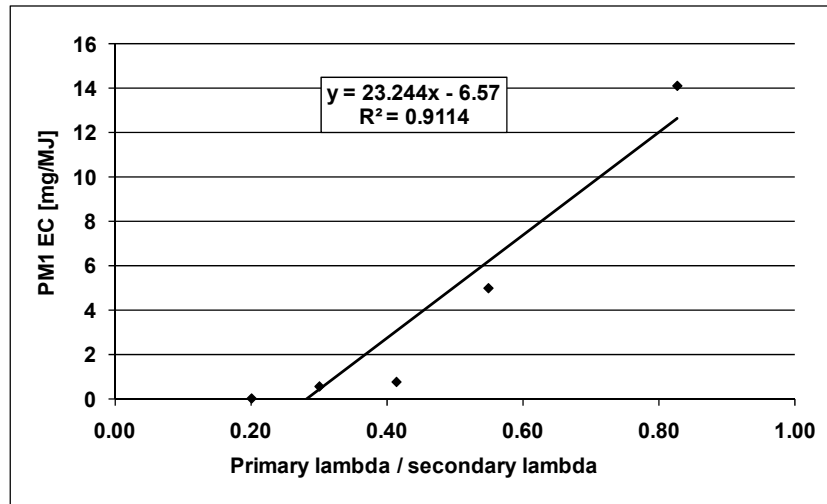



## Air staging strategies for residential heating boilers – residential pellet boiler – evaluation of the technology I

### ■ Results

- Decreased particle and CO emissions with decreased primary air. Opposite results with decreased secondary air.
- The relation between primary and secondary air-to-fuel ratios correlates with different emissions.
- Primary and total air ratios achieved in real operation  
Total air ratios (1.9 full load; 2.7 50% load) and calculated primary air ratios (0.6 full load; 1.2 50% load)



## Air staging strategies for residential heating boiler – Pellet boiler technology 1 – evaluation of the technology II

- **Conclusions regarding the research performed**
  - It is possible to decrease emissions with further optimization of secondary and primary air.
  - Air staging has a large effect on PM1 emissions.
- **Does the control concept support the air staging concept by an appropriate control of the air flows/flue gas recirculation during different combustion / load phases?**
  - Air flows are controlled based on fan frequencies.



## Air staging strategies for residential heating boiler – Pellet boiler technology 1 – evaluation of the technology III

- **Does the concept also appropriately work at partial load?**
  - **Yes. However, partial load produces higher emissions and higher air-to-fuel ratios.**
- **Potentials for optimisation**
  - **A lot of potential for optimisation. Decrease in the power output must be considered when decreasing primary air flow rate.**



## Air staging strategies for residential automated boilers – pellet burner based on gasification and combustion – introduction

- **Small-scale pellet burner**
- **manufactured by Pyroman Oy**
- **15 kW maximum output**
- **Top-feed fuel supply**
- **Computer-controlled fuel supply based on gasification algorithm**
- **Counter-draft fixed bed gasification on grate**
- **Ignition of the product gas by spark plug**
- **Primary, secondary and tertiary air**
  - **Primary air inlet under the grate in the gasification chamber**
  - **Secondary air is mixed with the gasification product in the burner head**
  - **Tertiary air is supplied at the end of the burner head**





## Air staging strategies for residential automated boilers – pellet burner based on gasification and combustion – description of technology I

### ■ Basic data

- Name of technology: Pellet burner based on gasification combustion
- Manufacturer: Pyroman Oy

### ■ Basic information about the combustion concept

- Nominal boiler capacity range in kW<sub>th</sub>: 15
- Fuels used: wood pellets
- Boiler technology: can be mounted in biomass and oil boilers
- Fuel feeding system: top-feed system



## Air staging strategies for residential automated boilers – pellet burner based on gasification and combustion – description of technology II

- **Basic information about the combustion concept (continued)**
  - **Grate technology: fixed grate (moves periodically)**
  - **Geometry of the furnace: burner head is of cylinder-form, furnace depends where installed**
  - **Furnace materials and insulation:**
    - Ceramic burner head
    - The burner is partially thermally insulated
    - Gasifier walls are air-cooled



## Air staging strategies for residential automated boilers – pellet burner based on gasification and combustion – description of technology III

- **Basic information about the combustion concept (continued)**
  - **General description of the control strategy:**
    - Product gas temperature is measured continuously and taken as input into the gasification control
    - Automatic fuel bed level control
  - **Partial load behaviour & possible loading:**
    - 3-15 kW with continuous operation
  - **possible loading:** continuous operation at 30 – 100% of nominal load possible



## Air staging strategies for residential automated boilers – pellet burner based on gasification and combustion – description of technology IV

### ■ Basic information concerning the air staging strategy applied

#### ■ Combustion air distribution concept

- Counter-draft gasification principle
- Primary air on the bottom of the fuel bed
- Secondary air into the inlet of the burner head
- Tertiary air at the end of the burner head
- Only one flue gas fan used to supply air flows.
- Primary/secondary air ratios are not regulated separately

#### ■ Flue gas recirculation: No flue gas recirculation



**Air staging strategies for residential automated boilers – pellet burner based on gasification and combustion – pictures/schemes of technology I**

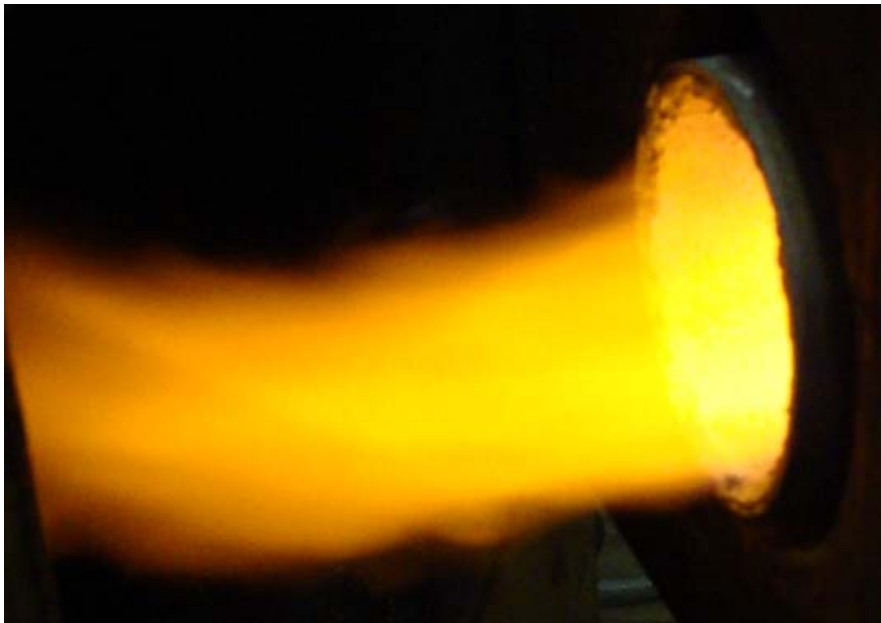



**Air staging strategies for residential automated boilers – pellet burner based on gasification and combustion – pictures/schemes of technology II**

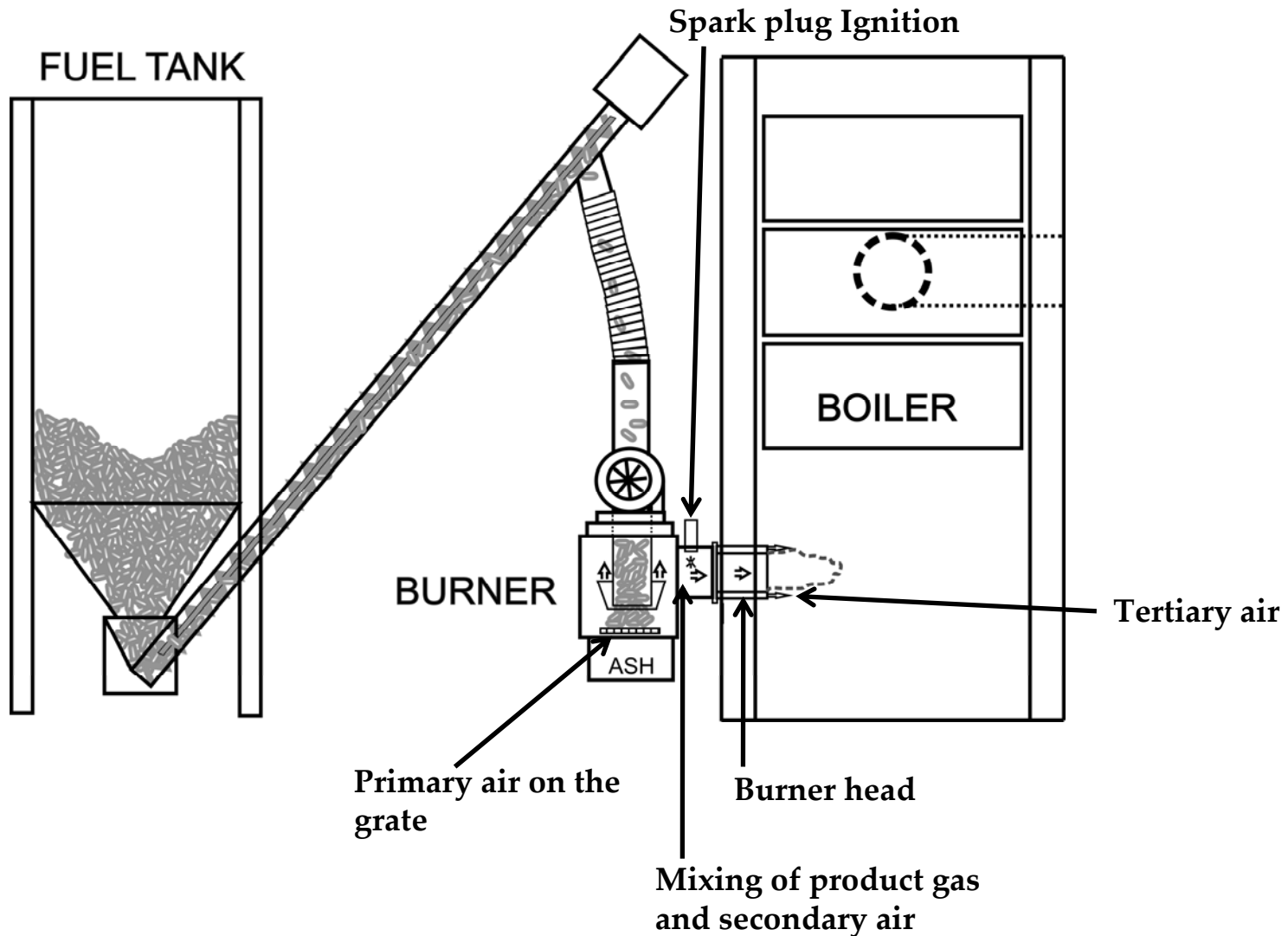



## Air staging strategies for residential automated boilers – pellet burner based on gasification and combustion – emissions (in mg/MJ) and efficiency I

### ■ Data from own measurements (UEF, Nuutinen et al., 2010)

- **CO:**
  - » At full load: 4-6 mg/MJ
  - » At partial load: n/a
- **OGC:**
  - » At full load: n/a
  - » At partial load: n/a
- **NO<sub>x</sub>:**
  - » At full load: 106-125 mg/MJ (as NO<sub>2</sub> equivalent)
  - » At partial load: n/a
- **Total dust:**
  - » At full load: 1.8 – 2.0 mg/MJ
  - » At partial load: n/a
- **PM<sub>1</sub>:**
  - » At full load: 1.3-2.4 mg/MJ
  - » At partial load: n/a
- **Efficiency:**
  - » At full load: n/a
  - » At partial load: n/a



## Air staging strategies for residential automated boilers – research performed on pellet burner based on gasification and combustion

- **Objectives of the research work performed**
  - **Determination of fine particle and gaseous emissions of a pellet burner based on counter-draft gasification**
  
- **Methodology applied**
  - **Diluting sampling system (porous tube + ejector) for aerosol sampling**
    - CO<sub>2</sub> used as marker gas for dilution ratio measurement
  - **PM1 measurement with PTFE filter collections from diluted sample**
  - **PM1 chemical characterization by ICP-MS, IC and thermal-optical carbon analysis**
  - **Particle number concentration and size distribution by ELPI and FMPS analyzers**
  - **TSP measurements by in-stack isokinetic sampling on plain filter**
  - **Gas emission measurements by FTIR**





# Air staging strategies for residential automated boilers – research performed on pellet burner based on gasification and combustion – measurement setup

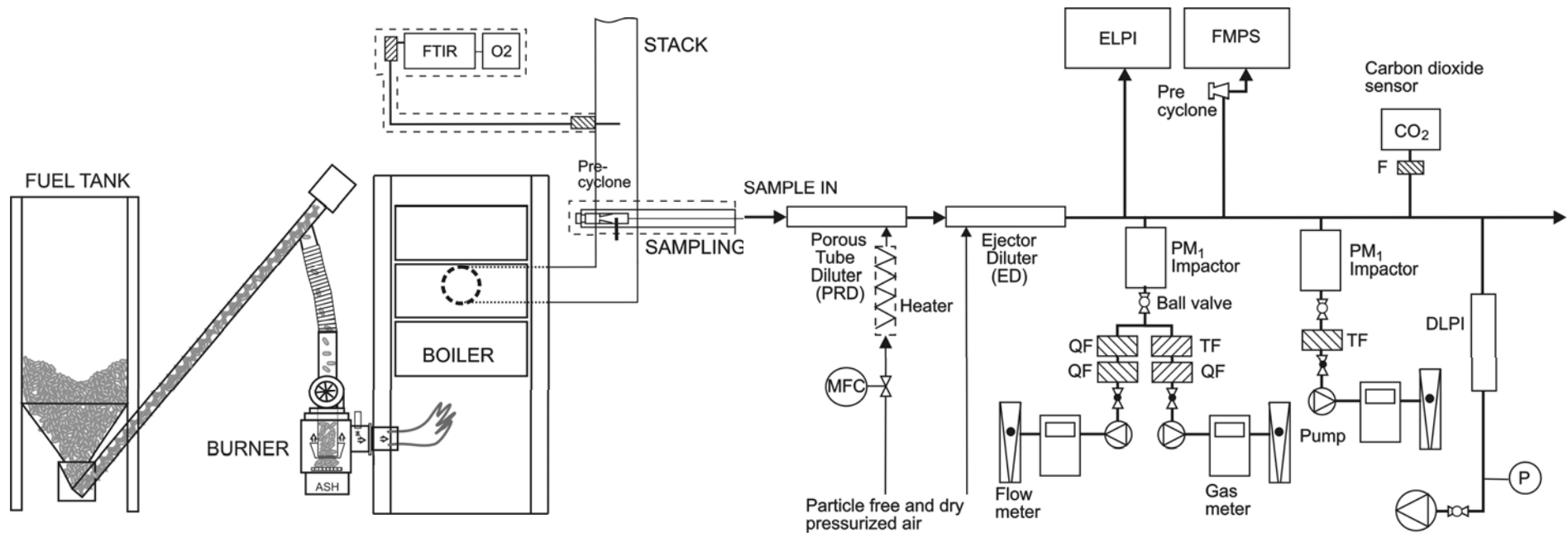



## Air staging strategies for residential automated boilers – research performed on pellet burner based on gasification and combustion - results

### ■ Results (Nuutinen et al., 2010)

- Very low PM1, TSP and CO emissions.
- Total air ratio: 1.6 – 1.7
- PM1 consists entirely of inorganic elements
- The release of alkali metals from the fuel is very low

### ■ Conclusions

**Counter-draft gasification technology is feasible for small-scale burners to provide efficient combustion with low emissions. The achieved very low PM1 emission is a significant step towards environmentally friendly small-scale biomass combustion systems**



## Air staging strategies for residential automated boilers – pellet burner based on gasification and combustion – evaluation of the technology I

- **Primary and total air ratios achieved in real operation**  
Total air ratio: 1.6 – 1.7
- **False air measurements/calculations – if available**  
n/a
- **Does the control concept support the air staging concept by an appropriate control of the air flows/flue gas recirculation during different combustion / load phases?**
  - Air flows are controlled based on fan frequency
  - The ratios of primary/secondary/tertiary air are not controlled
- **Does the concept also appropriately work at partial load?**
  - According to online gas measurements, there are no considerable changes in emissions at partial load. The air-to-fuel ratio remains low at partial load.



## **Air staging strategies for residential automated boilers – pellet burner based on gasification and combustion – evaluation of the technology II**

### **■ Conclusions regarding the research performed**

**Counter-draft gasification technology is feasible for small-scale burners to provide efficient combustion with low emissions. The achieved very low PM1 emission is a significant step towards environmentally friendly small-scale biomass combustion systems.**

### **■ Potentials for optimisation**

**Potential for decreasing the total air-to-fuel ratio (and increasing efficiency) without increasing emissions still exists.**



## References

- Lamberg, H., Sippula, O., Tissari, J. and Jokiniemi J. 2009. Effect of operating condition on emissions from a small scale pellet boiler. Bioenergy 2009–International Bioenergy Conference, Jyväskylä, Finland.
- Nuutinen, I., Sippula, O., Tissari, J., Jokiniemi, J. (2010) Fine particle and gas emissions of a pellet burner based on gasification combustion. Proceedings from the International Aerosol Conference 2010, August 29 – September 3, 2010 Helsinki.



# Summary and Evaluation of Existing Data on Air Staging Strategies in Sweden

**Country report**

**Prepared by Umeå University, Luleå University of Technology and SP Technical Research Institute**

**Project ERA-NET “Future BioTec”**



## Introduction

In general, very little dedicated R&D work has been performed in Sweden with specific focus on air staging as a measure for minimisation of PM. For NO<sub>x</sub>, CO and THC, it has been applied more extensively, however not always as well documented R&D projects.

The report from Sweden focuses on **four cases** where the “air staging” concept has been implemented and tested in a more systematic way to reduce emissions (PM and NO<sub>x</sub>):

### Medium sized combustion plants

A 500 kW<sub>th</sub> fixed grate fired furnace especially designed for wet and inhomogeneous biomass fuels (***research, development and commercial product***)

### Automated residential heating appliances

A commercial residential pellet stove (***research study on PM***)

A commercial residential pellet burner (***research study on NO<sub>x</sub>***)

### Special research reactors

***Research reactor*** (5 kW) for grate combustion of pellets



## Air Staging Strategies in Sweden - overview over the technologies investigated

- **Automated residential heating boilers (pellets, logwood and wood chips, up to 100 kW)**
  - A modified commercial residential pellet stove (*Technology I*)
  - A commercial residential pellet burner + lab. reactors (*Technology II*)
  - A research reactor (5 kW) for grate combustion of pellets (*Technology III*)
  
- **Medium sized fire-tube boilers (up to some MW)**

A 500 kW<sub>th</sub> grate fired furnace especially designed for wet and inhomogeneous biomass fuels (*Technology IV*)
  
- **Water tube steam boilers (up to 20 MW)**

*Not available (n.a.)*





## Air staging strategies for **automated residential heating boilers (up to 100 kW) – Technology I:** Research on a modified commercial residential pellet stove (*i*)

- **Basic data**
  - Name of technology: **Residential pellet stove**
  - Manufacturer: **Pitekaminen**
  
- **Basic information about the combustion concept**
  - Nominal fuel power input in  $\text{kW}_{\text{th}}$ : **2-6  $\text{kW}_{\text{th}}$**
  - Fuels used: **Pellets (normally stemwood based softwood)**
  - Fuel feeding system: **Screw conveyor**  
Grate technology: **Fixed grate**
  - Geometry of the furnace: **Vertical cylindrical combustion chamber with primary and secondary combustion zone separated by air distribution**



**Air staging strategies for automated residential heating boilers (up to 100 kW) – *Technology I*: Research on a modified commercial residential pellet stove (ii)**

– **Basic information about the combustion concept (cont.)**

- Furnace materials and insulation: **Insulated furnace walls of stainless steel**
- General description of the control strategy: **Load control by adjusting fuel feeding and air supply automatically**
- Partial load behaviour: **Continuous operation between 2-6 kW (i.e. 30-100% load)**





## Air staging strategies for automated residential heating boilers (up to 100 kW) – *Technology I*: Research on a modified commercial residential pellet stove (*iii*)

- **Basic information concerning the air staging strategy applied**
  - Combustion air distribution concept and geometric concept of the furnace with respect to air staging (*Info from research project by Wiinikka and Öhman, 2006*)

The grate is made from stainless steel and the bottom of the grate is perforated with holes and the open area of the grate is 2 %.

In the combustion chamber the, secondary air is introduced through 5 vertical rows with 6 holes in each row.

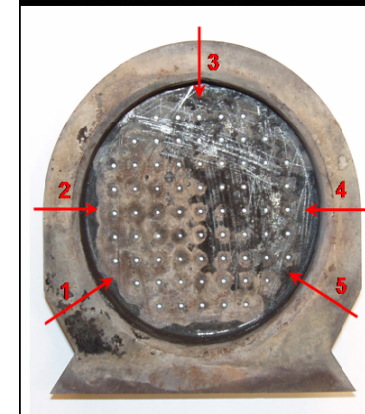



**Air staging strategies for automated residential heating boilers (up to 100 kW) – *Technology I*: Research on a modified commercial residential pellet stove (*iv*)**

- **Basic information concerning the air staging strategy applied (cont.)**
  - Flexibility concerning air staging and air distribution setup:  
**In commercial stoves, no flexibility to control/adjust air staging**  
**In the research study, no info available!**
  - Combustion air and air distribution controls applied:  
**n.a.**



## Air staging strategies for automated residential heating boilers (up to 100 kW) – *Technology I: Emissions (i)*

- Data provided by the manufacturer or type testing data

*Type testing according to Swedish P-marking at SP Technical Research Institute of Sweden  
(conversion from given data in mg/Nm<sup>3</sup> to mg/MJ made by division by 2.2)*

- CO: <180 mg/MJ
- OGC: <3 mg/MJ
- NO<sub>x</sub>: <60 ppm
- Total dust: 5 mg/MJ
- Efficiency: 87-93%



## Air staging strategies for automated residential heating boilers (up to 100 kW) – *Technology I: Emissions (ii)*

- Data from own measurements

### *Emission of PM<sub>2.5</sub>*

*(from Wiinikka and Öhman, 2006)*

**3.7 kW:**  $15 \pm 2.5$  mg/MJ

**6.2 kW:**  $9.5 \pm 0.5$  mg/MJ

Experimental description	PM <sub>2.5</sub> mg/Nm <sup>3</sup>	Soot wt %	Ash wt %
Middle effect (3.7 kW)			
Original stove	33.4±5.3	59	41
Grate open area 1 %	13.3±2.8	52	48
Grate open area 3 %	18.4±1.1	40	60
6 new holes in comb. cham.	14.0±0.5	31	69
2 new holes in comb. cham. location high	26.2±5.0	56	44
2 new holes in comb. cham. location low	10.5±0.8	48	52
Window insulation	15.3±2.4	32	68
High effect (6.2 kW)			
Original stove	20.8±0.9	45	55
Grate open area 1 %	20.8±2.6	58	42
Grate open area 3 %	19.9±1.4	25	75
6 new holes in comb. cham.	14.8±2.1	28	72
2 new holes in comb. cham. location high	19.2±2.9	51	49
2 new holes in comb. cham. location low	19.3±0.8	41	59
Window insulation	20.0±1.0	38	62



## Air staging strategies for **automated residential heating boilers (up to 100 kW)** – Research performed on *Technology I (i)*

- **Objectives of the research work performed (by ETC in Piteå and Luleå University of Technology)**

To demonstrate the possibilities to minimize the (fine) particle emissions from a commercial stove without significant reduction of other properties of the stove such as thermal efficiency and emissions of unburned gases.

- **Methodology applied**

Continuation of previous research in a lab-reactor used by Wiinikka in his PhD work. The stove was modified and the influence of three parameters studied;

- open area of the grate
- vertical hole row in the combustion chamber
- insulation of the window

Grate adjustments with reduced air flow may give less combustion intensity and lower temperature!



## Air staging strategies for automated residential heating boilers (up to 100 kW) – Research performed on *Technology I (ii)*

### Results

#### Open area of the grate

- At a fuel power input of 3.7 kW, the particle concentration in the flue gas stack was significantly affected by the open area of the grate.
  - Decreased carbon content of the PM, both when the open area was reduced from 2 % to 1 % and when it was increased from 2 % to 3 %.
  - Furthermore, the vaporization of ash is reduced when the open area of the grate is reduced from 2 % to 1 %.
- At 6.2 kW, no significant affect of the open area of the grate on the particle concentrations in the flue gas was found. However, the elemental composition of the particles was significant affected by the open area.
  - For example the carbon content of the particles emitted was 58 wt %, 45 wt %, and 25 wt % for an open grate area of 1 %, 2 %, and 3 %. This indicates that the emissions of soot are reduced and that the vaporization of ash is increased when the open area increases.





## Air staging strategies for automated residential heating boilers (up to 100 kW) – Research performed on *Technology I (iii)*

### Results (cont.)

#### New vertical row of holes

- At 3.7 kW the particle emissions were significantly affected both when a whole new row of holes (i.e. 6 new holes) and when 2 new holes, located near the grate, were introduced in the chamber. However, a non significant reduction was observed when 2 new holes were introduced in the upper part of the chamber.
- The reduction in particle concentration was probably coupled to a reduction of the unburned particles (presumably soot), since the carbon content decreased
- At 6.2 kW, the particle concentration in the flue gas channel was only affected when a whole new row of holes was introduced.
- This modification reduced the particle concentration from 20.8 mg/Nm<sup>3</sup> (original stove) to 14.8 mg/Nm<sup>3</sup>. This is probably again connected to a reduction of soot, since the carbon content of the particle was reduced from 45 to only 28 wt % (6 new holes).



## Air staging strategies for automated residential heating boilers (up to 100 kW) – Research performed on *Technology I (iv)*

### Results (cont.)

#### Insulation of the front window

- At 3.7 kW the particle emissions from the stove were affected by the window insulation. The PM was reduced from 33.4 mg/Nm<sup>3</sup> (no insulation) to 15.3 mg/Nm<sup>3</sup> when the window was insulated. The carbon content of the particle was also reduced from 59 wt % to 32 wt %.
- However, at 6.2 kW no significant reduction of particle concentration nor of the carbon content of the particle matter could be observed, indicating that the window insulation does not affect the emission of soot particles at high thermal loads.



## Air staging strategies for automated residential heating boilers (up to 100 kW) – Research performed on *Technology I (v)*

### Conclusions

- For the tested stove (PiteKaminen), both the soot particle and the fly ash particle concentrations were significant affected by the air flow rate through the grate.
- The “soot” particle concentration (carbon content) was significant affected by the air distribution in the combustion chamber and finally, the “soot” particle concentration was significant reduced when the window was insulated at 3.7 kW but not at 6.2 kW.
- The construction changes of the PiteKaminen performed in this work suggested that is possible to reduce the particle emissions up to 60 % at a stove effect of 3.7 kW and up to 30 % with a stove effect of 6.2 kW.
- Finally, it was possible to apply the knowledge on particle emission minimization obtained in our specially designed (research) reactor on a commercial wood pellets stove.



## Air staging strategies for **automated residential heating boilers (up to 100 kW)** – Evaluation of *Technology I (i)*

- **How is air staging implemented within the concept?**  
Controlled air staging is not implemented. Total air is however distributed as primary and secondary air that creates a primary and secondary part of the combustion chamber.
  
- **Does the control concept support the air staging concept by an appropriate control of the air flows/flue gas recirculation during different combustion/load phases?**  
NO!
  
- **Does the concept also appropriately work at partial load?**  
The design of the stove enables appropriate operation at low load (2 kW) with fixed distribution between primary and secondary air.



## Air staging strategies for **automated residential heating boilers (up to 100 kW)** – Evaluation of *Technology I (ii)*

- **Does the control concept support the air staging concept by an appropriate control of the air flows/flue gas recirculation during different combustion/load phases?**  
NO!



## Air staging strategies for **automated residential heating boilers (up to 100 kW) – Technology II: Research on a commercial residential pellet burner + lab.reactors (i)**

All info derived from a research project performed by Eskilsson et al., 2004

### ■ Basic data

- Name of technology: **Residential pellet burner + Lab. reactors**
- Manufacturer: **not relevant (n.r.)**

### ■ Basic information about the combustion concept

- Nominal boiler/burner capacity range in  $\text{kW}_{\text{th}}$ : **up to 15  $\text{kW}_{\text{th}}$**
- Fuels used: **Pellets (normally stemwood based softwood)**
- Fuel feeding system: **Screw conveyor**  
Grate technology: **Fixed grate**
- Geometry of the furnace: **n.r. (varies between different appliances used)**



## Air staging strategies for **automated residential heating boilers (up to 100 kW)** – *Technology II*: Research on a commercial residential pellet burner + lab.reactors (ii)

- **Basic information about the combustion concept (cont.)**
  - Furnace materials and insulation: not relevant (n.r.)
  - General description of the control strategy: n.r.
  - Partial load behaviour: n.r.
  
- **Basic information concerning the air staging strategy applied**
  - Combustion air distribution concept: varies between different appliances used
  - Geometric concept of the furnace with respect to air staging: see figure for one lab.reactor!
  - Flexibility concerning air staging and air distribution setup:  
In commercial burners, no flexibility!  
In the research study, no info available!
  - Combustion air and air distribution controls applied: varies between different appliances used



## Air staging strategies for automated residential heating boilers (up to 100 kW) – Research performed on *Technology II (i)*

### Objectives of the research work performed (by SP Swedish Technical Research Institute)

To study critical parameters for optimisation of NO<sub>x</sub>, OGC and CO emissions from pellet burners, both by experiments and kinetic modelling.

### Methodology applied

The project was divided into 4 stages:

1. Gas analyses in the combustion zone of a modified commercial pellet burner
2. Computer simulations (Chemkin) to study proper reaction times and temperatures for optimal NO<sub>x</sub> reduction
3. Detailed laboratory reactor studies of important parameters
4. Demonstration in a prototype burner





## Air staging strategies for **automated residential heating boilers (up to 100 kW)** – Research performed on *Technology II (ii)*

### Methodology applied (cont.) – Experimental appliances used:

- Commercial burner (PellX) - Horizontally fired burner
- Laboratory reactor studies
  - “Well defined combustion conditions”
  - Small batches of pellets (about 24 g) were combusted on a grate placed in a horizontal quartz glass reactor (inner diameter 70 mm) in an electrically heated furnace.
  - Primary combustion air was supplied through the grate. A flow of nitrogen (10 l/min) through the reactor tube ensured well-defined flow conditions.
- The “prototype” burner:

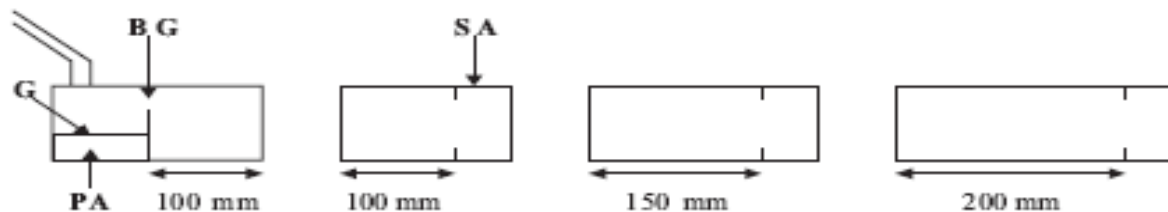

Fig. 2. Schematic design of the prototype burner. G = grate, BG = baffle, PA = primary air, SA = secondary air.



# Air staging strategies for automated residential heating boilers (up to 100 kW) – Research performed on *Technology II (iii)*

## Results – Commercial pellets burner

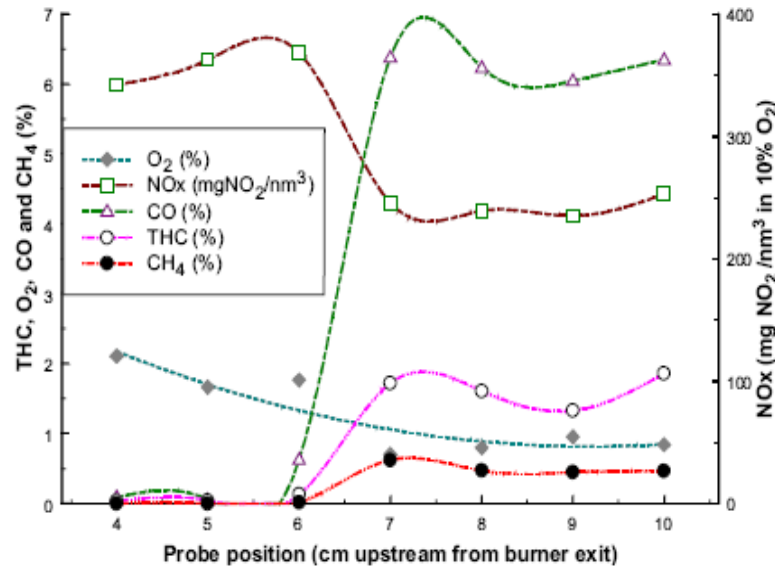

Fig. 3. An example of measured gas concentrations at different positions within the combustion chamber of a modified commercial pellet burner. The measured temperature in the primary zone is 1025 °C.

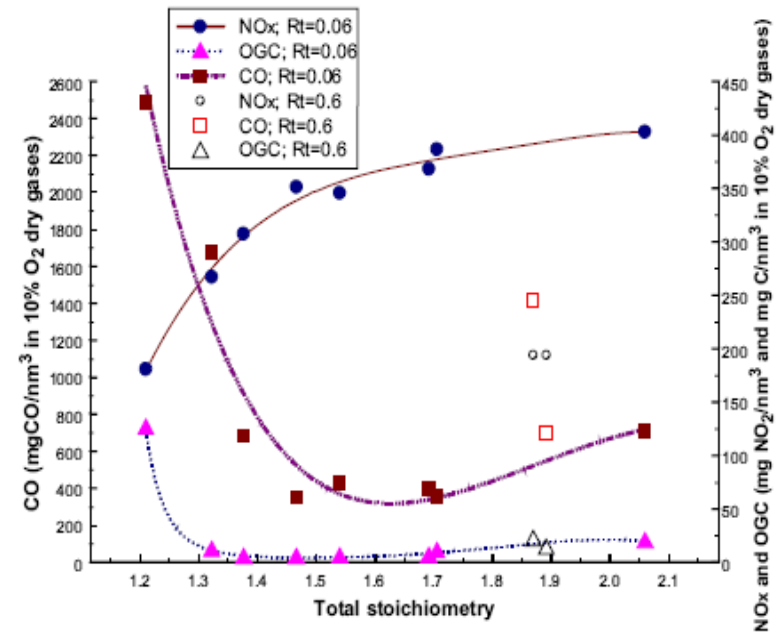

Fig. 5. Emissions of NO<sub>x</sub>, OGC and CO are shown for different stoichiometries for the modified commercial burner (residence time of 0.06 s). For comparison, the values for the prototype burner (residence time of 0.6 s) at a total stoichiometry of about 1.9 are indicated.



## Air staging strategies for automated residential heating boilers (up to 100 kW) – Research performed on *Technology II (iv)*

### Results – experimental lab.reactor

In the tests, the minimum concentrations of fixed nitrogen (the sum of  $\text{NO}_x$ ,  $\text{NH}_3$  and  $\text{HCN}$ ) were obtained after 200–400 ms. Data indicate that the  $\text{NO}_x$ -reduction was higher at 1100°C compared to 900°C.

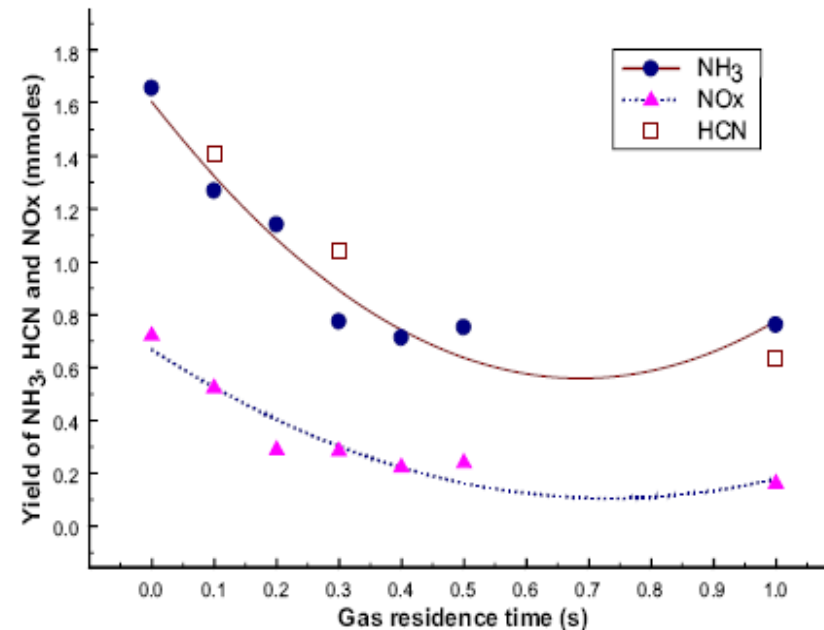

Fig. 4. The yield of  $\text{NH}_3$ ,  $\text{HCN}$  and  $\text{NO}_x$  during devolatilisation in batch combustion in a laboratory reactor at a furnace temperature of 1100 °C.



**Air staging strategies for automated residential heating boilers (up to 100 kW) – Research performed on *Technology II (v)***

## Results – Experimental prototype burner

Compared to the modified commercial burner, the NO<sub>x</sub> emissions decreased by 45%, still with minimum emission of hydrocarbons (4 mg C/nm<sup>3</sup>, at 10% O<sub>2</sub>).

The results indicate that the excess air ratio in the primary zone should be between 0.4 and 0.8, the temperature between 900 and 1100 °C and the residence time for the gas in the primary zone about 300 ms, which is about 5 times longer than the residence time in the modified commercial burner.

Simultaneously, the total excess air should be minimised. The burner should be designed in such a way that a well defined primary zone is established. The primary air should be supplied through the fuel bed and it is important that back mixing from the secondary air supply is avoided.



**Air staging strategies for automated residential heating boilers (up to 100 kW) – Research performed on *Technology II (vi)***

## Results – Modelling

As a result from the simulations, an optimal temperature for NO reduction was found to be about 900 °C.

The necessary residence time for the gas in the primary zone was about 300 ms. At higher temperatures, the required residence time in the primary zone decreased but unfortunately also the NO<sub>x</sub> reduction.

The simulations indicated that staging the secondary air could be an efficient way of achieving a high NO<sub>x</sub>-reduction.



Air staging strategies for **automated residential heating boilers (up to 100 kW)** – Research performed on *Technology II (vii)*

## Conclusions

Relatively simple design modifications can significantly decrease NO<sub>x</sub> emissions from today's pellet burners.

Also, the emissions of CO and hydrocarbons can be minimised.

Decreasing the excess air ratio also results in a higher efficiency.



## Air staging strategies for **automated residential heating boilers (up to 100 kW)** – *Technology III*: Research reactor (5 kW) for grate combustion of pellets (*i*)

All info from research projects by Wiinikka et al. (see references III)

### ■ Basic data

- Name of technology: **not relevant (n.r.)**
- Manufacturer: **n.r.**

### ■ Basic information about the combustion concept

- Nominal boiler capacity range in  $\text{kW}_{\text{th}}$ : **up to 10 kW**
- Fuels used: **Pellets (normally stemwood based softwood)**
- Fuel feeding system: **Screw conveyor, top feed technology**  
Grate technology: **Fixed grate**
- Geometry of the furnace: **Vertical cylindrical combustion chamber with primary and secondary combustion zone separated by air distribution (see Figures)**



**Air staging strategies for automated residential heating boilers (up to 100 kW) – *Technology III*: Research reactor (5 kW) for grate combustion of pellets (ii)**

- **Basic information about the combustion concept (cont.)**
  - Furnace materials and insulation: **Stainless steel reactor**
  - General description of the control strategy: **n.r.**
  - Partial load behaviour: **Continuous operation down to approximately 2 kW.**





## Air staging strategies for automated residential heating boilers (up to 100 kW) – *Technology III*: Research reactor (5 kW) for grate combustion of pellets (*iii*)

- **Basic information concerning the air staging strategy applied**
  - Combustion air distribution concept and geometric concept of the furnace with respect to air staging

Wiinikka et al., 2006 and 2007

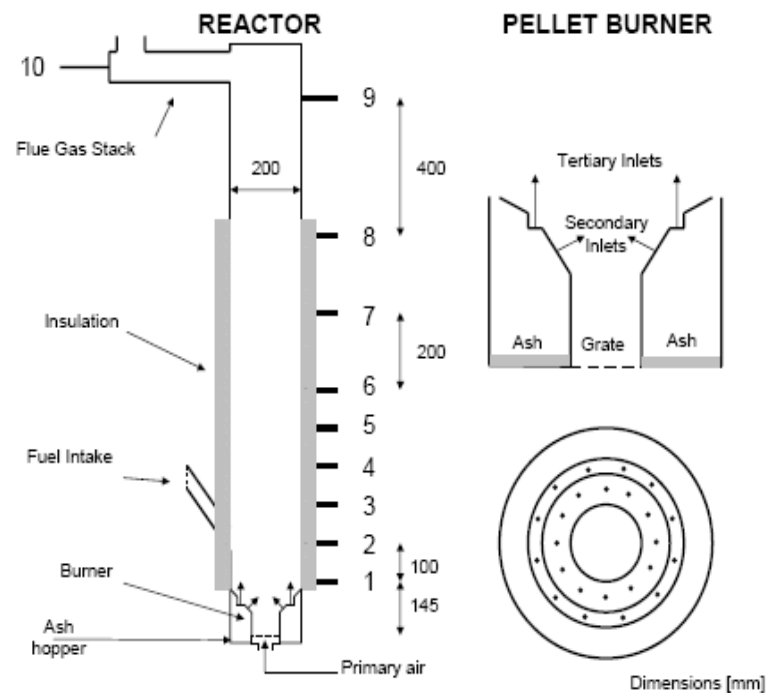

**Fig. 8.** Schematic sketch of the reactor and the pellets burner used in paper A and B. The location of the 9 sampling port in the reactor and the sampling port in the flue gas channel (port 10) are also showed.



## Air staging strategies for **automated residential heating boilers (up to 100 kW) – Technology III: Research reactor (5 kW) for grate combustion of pellets (iv)**

- **Basic information concerning the air staging strategy applied (cont.)**
  - Combustion air distribution concept and geometric concept of the furnace with respect to air staging

Wiinikka et al., 2004a,  
2004b, 2005a, 2005b

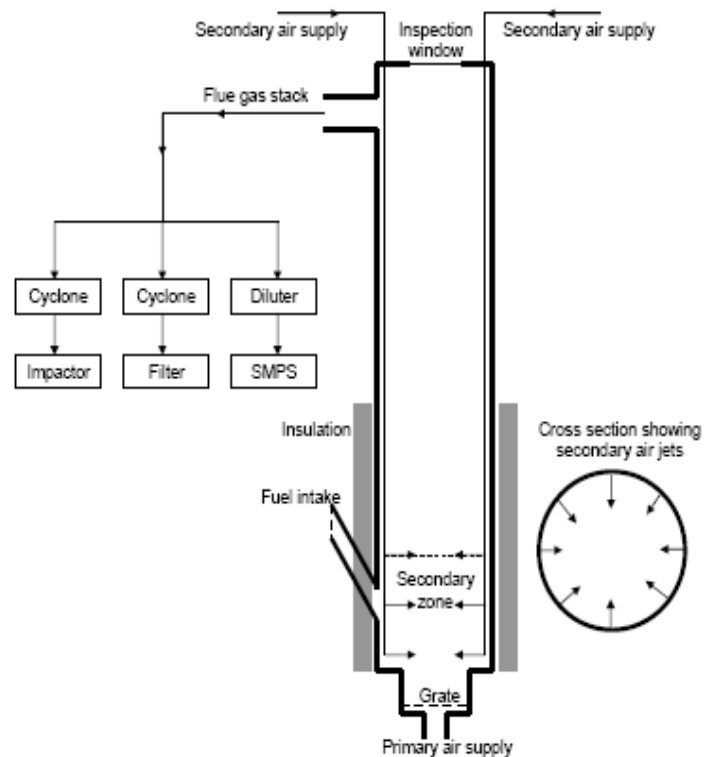

**Fig. 9.** Schematic sketch of the reactor and the pellets burner used in paper C-E. The sampling system used to sample particles from the flue gas channel are also showed.



## Air staging strategies for automated residential heating boilers (up to 100 kW) – *Technology III*: Research reactor (5 kW) for grate combustion of pellets (v)

### ■ Focuses in the research:

#### Formation of aerosols from wood pellet combustion

- Detailed measurements of high temperature aerosols
- Influence of fuel ash type on high temperature aerosols
- Formation of supermicron particles ( $> 10 \mu\text{m}$ )
- Vaporisation of metals (chemical equilibrium model calculations)

→ *Formation mechanisms for combustion aerosols*

#### Particle emission minimisation during wood pellets combustion

- Influence of combustion aerodynamics and temperature
- Influence of fuel type
- Influence of air supply strategy



## Air staging strategies for automated residential heating boilers (up to 100 kW) – *Technology III*: Research reactor (5 kW) for grate combustion of pellets (vi)

### Results - Influence of combustion aerodynamics and temperature

Significant effects on the particle emissions were found for the combustor wall temperature (process temperature) and the flow pattern in the reactor.

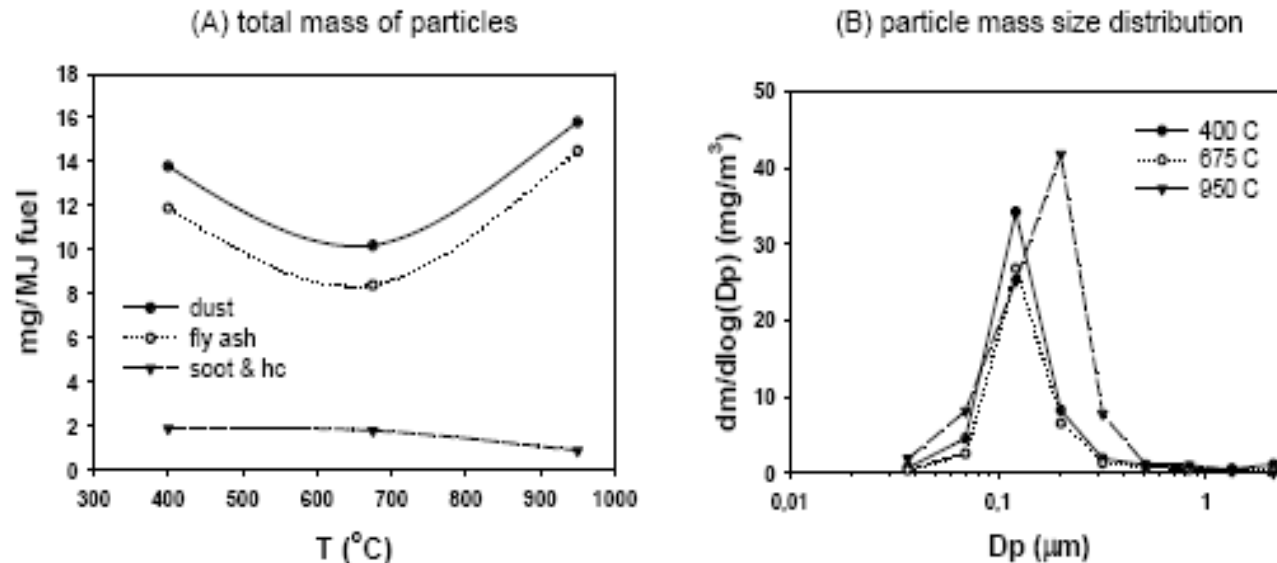

Fig. 17. Effect of combustor wall temperature on (A) the total mass of particles and (C) on the particle mass size distribution. Note that dust = fly ash + soot and other hydrocarbons (paper C).



## Air staging strategies for automated residential heating boilers (up to 100 kW) – *Technology III*: Research reactor (5 kW) for grate combustion of pellets (*vii*)

### Results - Influence of air supply strategy

The results show a significant reduction of the submicron particle size with decreasing air supply to the fuel bed, probably due to lower oxygen concentration in the fuel bed and thereby lower temperature in the burning char particles that would result in lower vaporisation of ash elements.

The emissions of supermicron particles were also affected by the air supply strategy with minimum of supermicron particles in the flue gas when the air was equally divided between the primary and secondary zone.

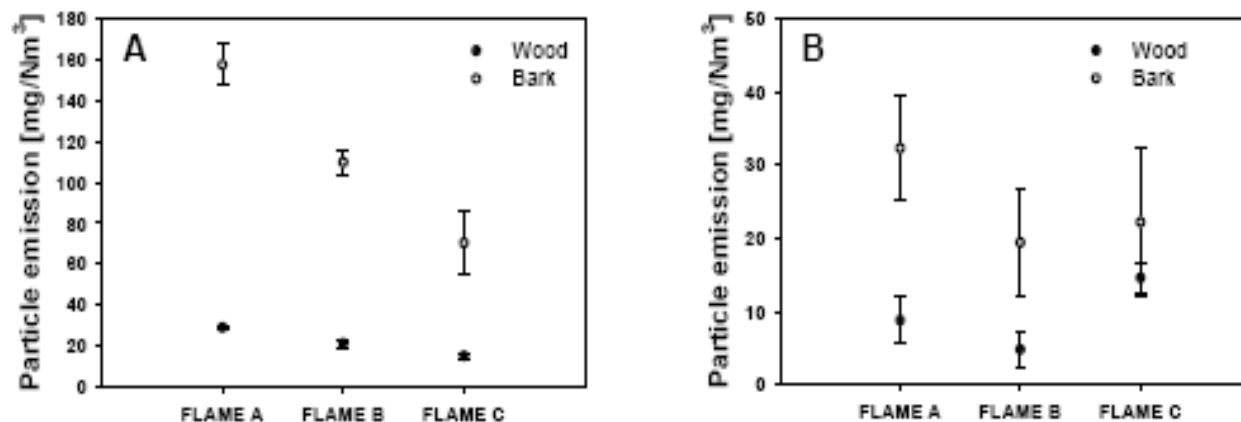

Fig. 19. Influence of the air supply strategy on the emissions of submicron particles (A) and supermicron particles (B). In Flame A, all the air was inserted through the grate (primary zone). In Flame B, the combustion air was equally divided between the primary and the secondary zone and in Flame C all the air was inserted through the secondary zone (paper E).



## Air staging strategies for automated residential heating boilers (up to 100 kW) – *Technology III*: Research reactor (5 kW) for grate combustion of pellets (*viii*)

### Conclusions – Related to PM reduction

- The particle emissions in the flue gas channel are affected by both operating and fuel parameters.
- The temperature and the flow pattern in the combustion zone affect the particle emissions.
- Increasing combustion temperature increases the formation of submicron fly ash particles. However, the emission of soot decreases.
- Increased mixing rate in the combustion chamber will also decrease the emissions of soot particles.
- In addition to the operating conditions significant differences in particle emissions were found between different biomass fuels.
- For the particles that were dominated by ash elements the particle emissions were correlated to the ash concentration in the unburned fuel.
- Furthermore, the results showed that in general the fuel type affects the (inorganic) particle emissions more than the influence from different operating and construction parameters.



## Air staging strategies for **Medium sized fire-tube boilers (up to some MW)** – *Technology IV*: A 500 kW grate fired furnace (i)

- **Basic data**
  - Manufacturer: **Swebo Bioenergy** (in collaboration with Luleå University of Technology)
- **Basic information about the combustion concept**
  - Nominal boiler capacity range in  $\text{kW}_{\text{th}}$ : **500  $\text{kW}_{\text{th}}$**
  - Fuels used:  
The boiler is **specially designed for wet fuels**. Normally in operation wood chips (about 58 % moisture) are used and also horse manure have been used/tested.
  - Boiler technology: **Fire tube**
  - Fuel feeding system:  
**Three fuel feeding screws** are used to transport the fuel from an intermediate fuel store into the furnace. The fuel enters the combustion chamber at a first horizontal plane and moves slowly towards a slope. The purpose of the two planes is to dry the fuel before the combustion process starts, using heat transfer by radiation and convection from the combustible gases.



**Air staging strategies for Medium sized fire-tube boilers (up to some MW) – *Technology IV*: A 500 kW grate fired furnace (ii)**

- **Basic information about the combustion concept (continued)**
  - Grate technology: **Fixed grate**
  - Geometry of the furnace: **see info on slide 185 and figure on slide 187**
  - Furnace materials and insulation: **not available (n.a.)**
  - General description of the control strategy: **n.a.**
  - Partial load behaviour: **very good partial load operation!**





## Air staging strategies for Medium sized fire-tube boilers (up to some MW) – *Technology IV*: A 500 kW grate fired furnace (iii)

- **Basic information concerning the air staging strategy applied**

- Combustion air distribution concept:

Primary air is injected above the fuel bed on both sides and also in front of the combustion chamber. No air through the grate.

- Geometric concept of the furnace with respect to air staging:

The primary combustion chamber is of a counter-current grate type, i.e. flame direction is the opposite of the fuel flow. This type is appropriate for wet biomass fuels, due to the increased convective heat transfer contributing to an improved drying process of the fuel.

The primary combustion chamber (i.e. primary air supply zone) is clearly separated from the secondary chamber.

The secondary combustion chamber is cylindrically shaped in order to create a re-circulating flow and thereby enhance the large scale mixing and the combustion intensity. To achieve good burn out, pre-heated (a few 100 °C) secondary air is injected at high velocities. Typical residence time in the secondary chamber is in the range of 0.6–1.6 s. The design was developed on the basis of CFD simulations and previous experiments. A thorough description of the design of the primary and secondary combustion chamber can be found in *Lundgren et al. (2003, 2004a,b, 2005)*.



## Air staging strategies for **Medium sized fire-tube boilers (up to some MW)** – *Technology IV*: A 500 kW grate fired furnace (iv)

- **Basic information concerning the air staging strategy applied (cont.)**
  - Flue gas recirculation: **No**
  - Flexibility concerning air staging and air distribution setup: **Controllable primary to secondary air ratio**
  - Combustion air and air distribution controls applied:  
Today at the test facility, the air and fuel supply is fully controllable and complemented with flue gas measurements of O<sub>2</sub>, CO and NO. (For commercial appliances info n.a.)
  - **SUMMARY:**
    - Effective drying of the fuel
    - Low temperature at the grate
    - High temperature and mixing in the secondary zone



**Air staging strategies for Medium sized fire-tube boilers (up to some MW) – Technology IV: A 500 kW grate fired furnace (v)**

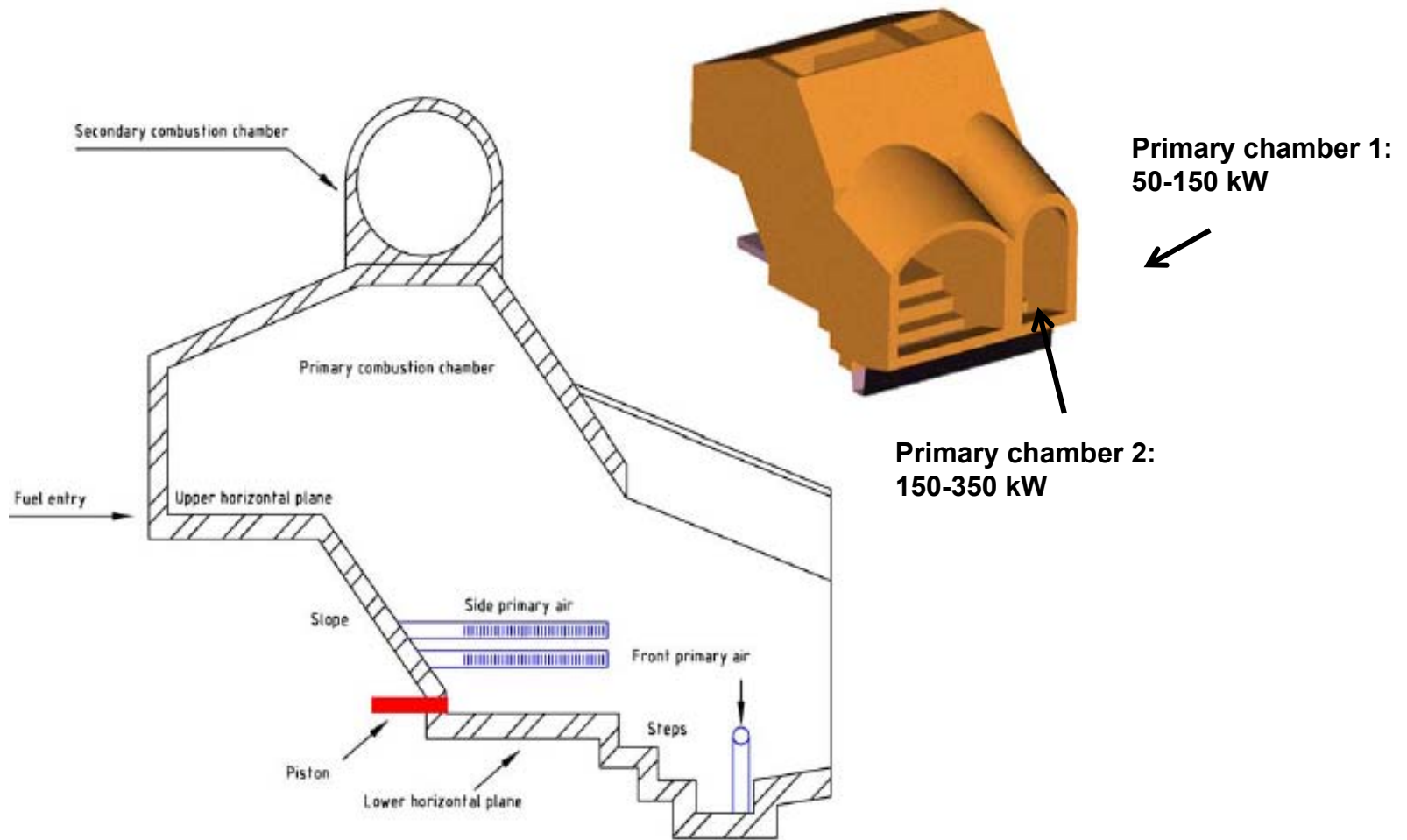

Fig. 2. 3-D- and side view of the combustion chamber.



## Air staging strategies for Medium sized fire-tube boilers (up to some MW) – *Technology IV*: Emissions (i)

- **Data from own measurements**

- Description of emission measurement methods

Heated probe and gas sample line maintained at a constant temperature of 120 °C immediately after the heat transfer unit.

A multi-component gas analyser for online measurements of NO, CO, CO<sub>2</sub> and O<sub>2</sub> (Maihak) and heated THC analysis (JUM).

NO/NO<sub>2</sub> converter (JNO<sub>x</sub>) to measure total NO<sub>x</sub> emissions.



## Air staging strategies for Medium sized fire-tube boilers (up to some MW) – *Technology IV: Emissions (ii)*

### Data from *Lundgren et al., 2004a*

- **CO:**
  - 12-100% load: < 10 mg/MJ
  - 10% load: 47 mg/MJ
- **OGC:**
  - 10-100% load: < 0.5 mg/MJ (as THC)
- **NO<sub>x</sub>:**
  - 10-100% load: 55-85 mg/MJ (as NO<sub>2</sub>)
- **Total dust:**
  - n.a.
- **PM<sub>1</sub>:**
  - n.a.
- **Efficiency:**
  - 83% (calculated for operation at 150-350 kW)



## Air staging strategies for **Medium sized fire-tube boilers (up to some MW)** – Research performed on **Technology IV (i)**

From *Lundgren et al., 2004a (Luleå University of Technology)*

### ■ Objectives of the research work performed

The aim of this experimental study has been to evaluate the performance of the combustion chamber at constant thermal output. Experiments have been carried out to verify the wide thermal output span and the furnace's ability to handle fuel with high moisture content, with maintained low emissions of unburnt gases.

### ■ Methodology applied

Thermal output was varied (50-500 kW) and CO used as indicator on combustion quality. Experiments with different settings of the ratio between front- and side primary air as well as the ratio between total primary- and secondary air were performed in order to study the effects on emissions and excess air.

### ■ Results

The experiments show very good results over the entire thermal output range. In the range 60 kW up to 500 kW, the average CO content in the stack gases is typically below 25 mg/Nm<sup>3</sup> (20 ppm) and the NO<sub>x</sub> concentration below 195 mg/Nm<sup>3</sup> (95 ppm) during steady state conditions. At lower thermal outputs, the average CO content is below 105 mg/Nm<sup>3</sup> (84 ppm). (All values standardised to 10 vol% O<sub>2</sub>, dry flue gas)



## Air staging strategies for **Medium sized fire-tube boilers (up to some MW)** – Research performed on *Technology IV (ii)*

### Conclusions

Experiments at constant thermal output, in the range 60–500 kW, show very good results considering emissions of CO and THC. The average CO content in the stack gases during the presented tests is below 25 mg Nm<sup>3</sup>. Moisture contents of the fuel up to around 58% do not seem to affect the combustion process negatively, when the large combustion chamber is in operation.



## Air staging strategies for **Medium sized fire-tube boilers** (up to some MW) – Research performed on **Technology IV (iii)**

From *Lundgren et al., 2004a (Luleå University of Technology)*

- Primary and total air ratios achieved in real operation

***Air/Fuel ratios ( $\lambda$ ) tested during research:***

At 150 kW:            Primary  $\lambda$  varied in the range 0.9-1.3  
                               Total  $\lambda$  varied in the range 1.5-1.8

At 350 kW:            Primary  $\lambda$  varied in the range 0.7-1.0  
                               Total  $\lambda$  varied in the range 1.4-1.6

- False air measurements/calculations:    **n.a.**
- How is air staging implemented within the concept?

The primary air is distributed between *front* and *side* injection points in a variable ratio.

The primary gases continue to the cylindrical ceramic secondary chamber. CFD simulations were used to optimize the secondary air supply in order to obtain good mixing.





## Air staging strategies for **Medium sized fire-tube boilers (up to some MW)** – Research performed on **Technology IV (iv)**

From *Lundgren et al., 2004a (Luleå University of Technology)*

- Does the control concept support the air staging concept by an appropriate control of the air flows/flue gas recirculation during different combustion / load phases?

**In the test/research facility (Lundgren et al., 2004a), the air staging concept was applied for different loads by manual adjustments of air flows (by mass flow controllers).**

- Does the concept also appropriately work at partial load?

**One of the unique features of this new furnace is the broad thermal output span, which makes it possible to run the boiler down to 10% of maximum heat load, with maintained low emissions of CO and total hydrocarbons (THC).**



## References (I)

### **Technology I: Modified commercial residential pellet stove**

Wiinikka H, Öhman M, (2006). *The effect of grate and combustor aerodynamics on particle emissions in a commercial wood pellets stove*. In: *Proceedings of the 2nd World Conference on Pellets, 30 May–1 June, Jönköping, Sweden*.

### **Technology II. Modified commercial residential pellet burner**

Eskilsson D, Rönnbäck M, Samuelsson J, Tullin C, (2004). *Optimisation of efficiency and emissions in pellet burners*. *Biomass and Bioenergy* 27, 541–546

Eskilsson D, Tullin C, (2001). *Sensorer för styrning och minimering av emissioner från småskalig biobränsleförbränning - förstudie*. Report from the Swedish Energy Agency, 2001. (In Swedish)

Reaction Design, The Chemkin Collection v3.6: Combustion Package, 6440 Lusk Blvd. Suite D209, San Diego, CA 92121, USA.

Zabetta EC, Kilpinen P, Hupa M, (2000). Kinetic modeling study of the potential of staged combustion in gasturbines for the reduction of nitrogen oxides emissions from biomass IGCC plants. *Energy and Fuel* 14, 751–61.



## References (II)

### **Technology III. Research facility (5 kW) for grate combustion of pellets**

Wiinikka H, Gebart R, Boman C, Boström D, Nordin A, Öhman M, (2006). *High temperature aerosol formation in wood pellets flames: Spatially resolved measurements.* Combustion and Flame 147, 278-293.

Wiinikka H, Gebart R, Boman C, Boström D, Öhman M, (2007). *Influence of fuel ash composition on high temperature aerosol formation in fixed bed combustion of woody biomass pellets.* Fuel 86, 181-193.

Wiinikka H, Gebart R, (2004a). *Critical parameters for particle emissions in small-scale fixed bed combustion of wood.* Energy and Fuels 18, 897-907.

Wiinikka H, Gebart R, (2004b). *Experimental investigations of the influence from different operating conditions on the particle emissions from a small-scale pellets combustor.* Biomass and Bioenergy 27(6), 645-652.

Wiinikka H, Gebart R, (2005a). *The influence of fuel type on particle emissions in combustion of biomass pellets.* Combustion Science and Technology 177, 741-763.

Wiinikka H, Gebart R, (2005b). *The influence of air distribution rate on particle emissions in fixed bed combustion of biomass.* Combustion Science and Technology 177, 1747-1766.



## References (III)

### **Technology IV. 500 kW grate fired reactor**

Lundgren J, Hermansson R, Lundqvist M, (2003). *Design of a secondary combustion chamber for a 350 kW wood-chips fired furnace*. In: Proceedings of the International Conference on Fluid and Thermal Energy Conversion, 7–11, December, Bali, Indonesia.

Lundgren J, Hermansson R, Dahl J, (2004a). *Experimental studies of a biomass boiler suitable for small district heating systems*. Biomass and Bioenergy 26 (5), 443–453.

Lundgren J, Hermansson R, Dahl J, (2004b). *Experimental studies during heat load fluctuations in a 500 kW wood-chips fired boiler*. Biomass and Bioenergy 26 (3), 255–267.

Lundgren J, Hermansson R, Dahl J, (2005). *New furnace designed for small-scale combustion of wet and inhomogeneous biomass fuels*. In: Proceedings of the 14th European Biomass Conference and Exhibition, 17–21 October, Paris, France.